

TRI PLANE FOLDING TRI PLANE



T. G. SCHMEISER

OPERATION AND PARTS MANUAL

Version 4.0
July 2019

Read and understand the manual. This manual provides information and procedures to safely operate and maintain the Tri Plane.





CONTENTS

INTRODUCTION.....	4	Rigid Tri Plane Assembly Procedure.....	18
Engineered for Long Life.....	4	Folding Tri Plane Assembly Procedure.....	20
Serial Number Information.....	4	To Transport Tri Plane on the Road.....	22
Replacement Parts.....	4	To Lower Tri Plane for Leveling.....	22
Warranty Information.....	4	Hydraulic Bucket Option.....	23
Serial Number Location.....	4	Hydraulic Diagram for Hydraulic Bucket Option.	23
Factory Contact Information.....	4		
Dealer Contact Information.....	4		
SPECIFICATIONS.....	5	MAINTENANCE.....	24
Tri Plane Rigid.....	5	Lubrication Points.....	24
Tri Plane Folding.....	5	Wheel Hub Bearings.....	24
SAFETY.....	6	Turnbuckles and Linkage.....	24
Safety Alert Symbols.....	6	Ground Engaging Components.....	24
Safety Icons Nomenclature.....	7	Bucket Blades.....	24
Personal Protection/Important Information..	7	Adjustable Side Blades.....	24
Prohibited Actions.....	7	Service Items.....	25
Hazard Avoidance.....	7	Tires.....	25
General Safety.....	8	Hydraulic Hoses.....	25
Assembly Safety.....	8	Maintenance Schedule.....	25
Towing Safety.....	8	STORAGE.....	26
Safety Chain.....	9	Storage Preparation.....	26
Highway and Transport Operations.....	9	Placing in storage.....	26
Operation Safety.....	10	Removing From Storage.....	26
Tractor Requirements.....	10	Disposal of Equipment at End of Useful Life.....	27
Tractor Safety Devices.....	10		
ROPS and Seat Belt.....	10	PARTS SECTION.....	28
Attaching to Tractor.....	10	Component Nomenclature.....	28
Prior to Connecting Unit.....	10	Component Location Tri Plane Rigid.....	28
Connecting to the Tractor.....	10	Component Location Tri Plane Folding.....	29
Hydraulic Component Safety.....	11	Parts Drawings.....	30
Maintenance Safety.....	12	Ordering parts.....	30
Tires Safety.....	12	Tri Plane Pull Frame Assembly.....	30
Bolt Torque Requirements.....	12	Front Turnbuckle Assembly.....	31
Tire and Lug Torque Specifications.....	13	Front Pivot Shaft Assembly.....	32
Welding Repairs.....	13	Front Wheel Frame Assembly.....	33
Storage Safety.....	13	Quad Tire Option Assembly.....	34
		Bucket Linkage Assembly.....	35
		Rigid Bucket Assembly.....	36
		Folding Bucket Assembly.....	38
		Bucket Blades Assembly.....	40
		Wheel Axle Assembly.....	41
		Rear Steel Wheel Frame Assembly.....	42
		Rear Cross Bar Assembly (Folding).....	44
		Front Wing Lockout Assembly (Folding)....	45
SAFETY SIGNS AND DECALS.....	14	HYDRAULIC DIAGRAM.....	46
Safety Sign Placement.....	14	LIMITED WARRANTY STATEMENT.....	47
Safety Signs and Decals.....	15		
SAFETY MARKING AND LIGHTING.....	16		
Tri Plane Rigid.....	16		
Tri Plane Folding.....	17		
ASSEMBLY AND OPERATION.....	18		

INTRODUCTION

Your Schmeiser Tri Plane Leveler (implement) is the ideal pre- and post-harvest tool for leveling fields. The Tri Plane Leveler will knock down the high spots and fill in the low areas with a single pass.

This manual has been prepared to instruct the user in the safe and efficient operation of this implement. Read and understand the manual thoroughly and follow all instructions carefully.

Engineered for Long Life

The Tri Plane Leveler is designed to provide many years of dependable service when used and maintained properly.

Serial Number Information

Record the serial number, model number, and date purchased in the space provided in the Serial Number Location section. Be sure to have this information whenever contacting the dealer to order parts or attachments for this implement.

Replacement Parts

Should this implement require replacement parts, contact your local Schmeiser dealer. Always order genuine Schmeiser OEM replacement parts.

Warranty Information

It is important that the Warranty Card be completed and sent to Schmeiser. The warranty will not be valid until the information is on file at Schmeiser. If information not contained in this manual is needed, contact your Schmeiser dealer.

Thank you for buying a Schmeiser Tri Plane Leveler.

Serial Number Location



Serial No. _____

Model No. _____

Date Purchased. _____

Dealer Name. _____

Factory Contact Information

For questions not answered in this manual, if additional copies are required, or the manual is damaged, please contact your local dealer or:

T. G. Schmeiser Co., Inc.
P.O. Box 1392
Selma, CA 93662

Phone: (559) 268-8128
Fax: (559) 268-3279
E-mail: sales@tgschmeiser.com
Web: www.tgschmeiser.com

Additional copies of this manual can also be downloaded at www.tgschmeiser.com.

Dealer Contact Information

For replacement decals, questions, or to order parts, contact your dealer:





SPECIFICATIONS

Tri Plane Rigid Models

Model	Size	Transport Width	Front Wheel Style	Weight	Recommended HP
SLP 12DS30	12 ft. X 30 ft.	12 ft.	Dual Steel Wheels	7040 lbs. (3193 kg)	115-140
SLP 12QR30	12 ft. X 30 ft.	12 ft.	Quad Rubber Tires	6640 lbs. (3012 kg)	115-140
SLP 14DS30	14 ft. X 30 ft.	14 ft.	Dual Steel Wheels	7190 lbs. (3261 kg)	130-155
SLP 14QR30	14 ft. X 30 ft.	14 ft.	Quad Rubber Tires	6790 lbs. (3080 kg)	130-155
SLP 16DS30	16 ft. X 30 ft.	16 ft.	Dual Steel Wheels	7330 lbs. (3325 kg)	150-175
SLP 16QR30	16 ft. X 30 ft.	16 ft.	Quad Rubber Tires	6930 lbs. (3144 kg)	150-175
SLP18DS30	18 ft. X 30 ft.	18 ft.	Dual Steel Wheels	7430 lbs. (3370 kg)	170-190
SLP 18QR30	18 ft. X 30 ft.	18 ft.	Quad Rubber Tires	7030 lbs. (3189 kg)	170-190
SLP 14DS	14 ft. X 40 ft.	14 ft.	Dual Steel Wheels	7490 lbs. (3398 kg)	130-155
SLP 14QR	14 ft. X 40 ft.	14 ft.	Quad Rubber Tires	7090 lbs. (3216 kg)	130-155
SLP 16DS	16 ft. X 40 ft.	16 ft.	Dual Steel Wheels	7630 lbs. (3461 kg)	150-175
SLP 16QR	16 ft. X 40 ft.	16 ft.	Quad Rubber Tires	7230 lbs. (3280 kg)	150-175
SLP 18DS	18 ft. X 40 ft.	18 ft.	Dual Steel Wheels	7730 lbs. (3507 kg)	170-190
SLP 18QR	18 ft. X 40 ft.	18 ft.	Quad Rubber Tires	7330 lbs. (3325 kg)	170-190

Tri Plane Folding Models

Model	Size	Transport Width	Front Wheel Style	Weight	Recommended HP
SLP 20DSF	20 ft. X 40 ft.	10 ft.	Dual Steel Wheels	9250 lbs. (4196 kg)	200-260
SLP 20QRF	20 ft. X 40 ft.	10 ft.	Quad Rubber Tires	8850 lbs. (4014 kg)	200-260
SLP 22DSF	22 ft. X 40 ft.	10 ft.	Dual Steel Wheels	9360 lbs. (4246 kg)	220-280
SLP 22QRF	22 ft. X 40 ft.	10 ft.	Quad Rubber Tires	8960 lbs. (4064 kg)	220-280
SLP 24DSF	24 ft. X 40 ft.	10 ft.	Dual Steel Wheels	9470 lbs. (4296 kg)	240-300
SLP 24QRF	24 ft. X 40 ft.	10 ft.	Quad Rubber Tires	9070 lbs. (4114 kg)	240-300

SAFETY

Carefully read and follow all safety precautions before operation. There are obvious and hidden potential hazards involved in the operation of this implement. Serious injury or death may occur unless care is taken to ensure the safety of both the operator and any other persons in the area. Avoid potential danger by taking extra time for thought and a more careful approach to the use of this implement.

Most work related accidents are caused by failure to observe basic safety rules or precautions. An accident can often be avoided by recognizing potentially hazardous situations before an accident occurs. As you assemble, operate, or maintain the unit, you must be alert to potential hazards. You should also have the necessary training, skills, and tools to perform any assembly or maintenance procedures.

Improper operation and maintenance of this unit could result in a dangerous situation that could cause injury or death. T.G. Schmeiser cannot anticipate every possible circumstance that might involve a potential hazard. The warnings in this manual and on the product are, therefore, not all-inclusive. If a method of operation not specifically recommended by us is used, you must satisfy yourself that it is safe for you and for others. You should also ensure that the unit will not be damaged or be made unsafe by the methods that you choose.

The information, specifications, and illustrations in this manual are based on the information that was available at the time this material was written and are subject to change without notice.

Safety Alert Symbols



This is the safety alert symbol. It is used to alert you to potential personal injury hazards.

Obey all safety messages that follow this symbol to avoid possible injury or death.

This manual contains DANGERS, SAFETY INSTRUCTIONS, CAUTIONS, IMPORTANT NOTICES, and NOTES which must be followed to prevent the possibility of improper service, damage to the equipment, personal injury, or death. The following key words call the readers attention to potential hazards.

Hazards are identified by the "Safety Alert Symbol" and followed by a signal word such as "DANGER", "WARNING", or "CAUTION".

DANGER

Indicates an imminently hazardous situation which, if not avoided, will result in death or serious injury. This signal word is limited to the most extreme situations.

WARNING

Indicates a potentially hazardous situation which, if not avoided, could result in death or serious injury.

CAUTION

Indicates a potentially hazardous situation which, if not avoided, may result in minor or moderate injury.

NOTICE

Indicates that equipment or property damage can result if instructions are not followed.

SAFETY INSTRUCTIONS

Safety instructions (or equivalent) signs indicate specific safety-related instructions or procedures.

Note: Contains additional information important to a procedure.

Safety Icons Nomenclature

This manual and the equipment has numerous safety icons.

These safety icons provide important operating instructions which alert you to potential personal injury hazards.

Personal Protection/Important Information

 READ THE MANUAL

 THINK SAFETY

 MAINTENANCE PROCEDURE

 WEIGHT RATING

 EYE PROTECTION

 HAND PROTECTION

 HEAD PROTECTION

 HEARING PROTECTION

 INSPECT EQUIPMENT

 OEM PARTS ONLY

 PLACE IN NEUTRAL

 PROTECTIVE SHOES

 REMOVE KEY

 DAMAGED HAZARD LABEL

 SLOW VEHICLE PLACARD

 SET PARKING BRAKE

 STOP ENGINE

 SUPPORT STAND USAGE

 USE PROPER TOOLS

 VISUALLY INSPECT

 USE ROPS

 USE CORRECT PARTS

Prohibited Actions

 DO NOT ALTER OR MODIFY

 DO NOT LEAVE OUT TOOLS

 DO NOT WELD

 NO ALCOHOL

 NO CHILDREN

 NO DRUGS

 NO PASSENGERS

 NO RIDERS

 NO BYSTANDERS

Hazard Avoidance

 BLOCK WHEELS

 CRUSHING HAZARD (body)

 CRUSHING HAZARD (foot)

 CRUSH HAZARD (rolling over)

 DEFECTIVE OR BROKEN PART

 FALLING HAZARD

 MAINTAIN SAFE DISTANCE

 OVERTURN HAZARD

 PINCH POINT HAZARD

 SAFETY ALERT SYMBOL

 SHARP OBJECT HAZARD

 ZERO PRESSURE

 COMPRESSED AIR HAZARD

 CRUSH HAZARD

 CRUSH HAZARD

 HIGH PRESSURE FLUID HAZARD

 HOT SURFACE HAZARD

 HEAVY OBJECT HAZARD

GENERAL SAFETY

WARNING



Read and Understand Manual

To prevent personal injury or even death, be sure you read and understand all of the instructions in this manual and other related OEM equipment manuals! This equipment is dangerous to children and persons unfamiliar with its operation. The operator should be a responsible adult familiar with farm machinery and trained in this equipment's operations. Do not allow persons to operate or maintain this unit until they have read this manual and have developed a thorough understanding of the safety precautions and how it works.

This unit was designed for a specific application; DO NOT modify or use this unit for any application other than that for which it was designed. Units operated improperly or by untrained personnel can be dangerous!



Fall Hazard

Do not use this implement as a work platform. Do not stand on top of the unit at

any time. Do not ride on the tractor or the implement or allow others to ride.



Crush Hazard (Rolling Over)

To prevent serious injury or death, before disconnecting, leaving the operator's seat, servicing, adjusting, repairing, or performing other work on the implement, ALWAYS:

1. Stop the tractor or towing vehicle.
2. Shut off the engine and remove the ignition key.
3. Set the brakes.
4. Make sure wheel cylinder transport lock is attached.
5. Relieve hydraulic fluid pressure.



Injury Hazard

Do not permit children to play on or around the unit.



Impaired Operator Hazard

Do not attempt to operate this unit under the influence of drugs or alcohol. Review the safety instructions with all users annually.



Pinch Point /Sharp Object Hazard

Do not place any body parts between moving and / or stationary parts. The weight of the implement will easily cause serious bodily injury.



To prevent injury, use a tractor equipped with a Roll Over Protective System (ROPS).



Visually Inspect

Visually inspect the unit for any loose bolts, worn parts, or cracked welds, and make necessary repairs before using the unit.

Personal Protection Equipment

When working around or operating this unit, wear appropriate personal protective equipment. This list includes but is not limited to:



- A hard hat
- Protective shoes with slip resistant soles
- Protective goggles, glasses, or face shield
- Heavy gloves and protective clothing
- Ear muffs or plugs



Use Properly Rated Tools

To prevent serious injury:

Use sufficient tools, jacks, and hoists that have the capacity for the job.



NO PASSENGERS ALLOWED

Do not carry passengers anywhere on or in the tractor or implement.



Rolling Hazard

To prevent serious injury, lock the wheels when performing assembly, maintenance, repairs, or when preparing for storage.

ASSEMBLY SAFETY

WARNING



Crush Hazard

Use support blocks or safety stands rated to support the load when

assembling the unit or performing maintenance.

Never work under equipment supported by hydraulics. Hydraulics can drop equipment instantly if controls are actuated even when power to the hydraulics is shut off.



Trapped Air Hazard

When installing, replacing, or repairing hydraulic system cylinders or parts, make sure that the entire system is charged and free of air before resuming operations. Failure to bleed the system of all air can result in improper machine operation, causing severe injury.

TOWING SAFETY

WARNING



Unexpected Separation Hazard

If the safety chain does not have a current certification tag, do not use the unit until properly certified chains are installed. Substandard safety chains could allow the unit to separate from the tow vehicle, resulting in equipment damage and personal injury.



Loss of Control

A minimum of 20% of the combined tractor and equipment weight should be on the front wheels to ensure adequate stability during transport and operation. To avoid serious injury or death from a loss of control accident, maintain 20% weight on the front wheels. Add front end weight if necessary.



Hitch and coupling on the towing vehicle must be rated equal to, or greater than, the unit's "gross vehicle weight rating" (GVWR).

SAFETY INSTRUCTIONS



Towing the implement requires care! Both the implement and tow vehicle must be in good working condition. Securely attach the unit to the tow vehicle using a high strength, appropriately sized hitch pin with a mechanical retainer and attach the safety chain.



Check the tires for tread wear, inflation pressure, and overall condition before towing the unit.



Inspect the hitch and coupling for wear or damage. DO NOT tow the unit using a defective hitch or coupling!



Make sure the lug nuts holding the wheels are tight (torque to specifications) and that none are missing.



Do not allow anyone to stand between the tongue or hitch and the towing vehicle when backing up to the unit.

Operate the towing vehicle from the operator's seat only.



When transporting, remember the implement may be wider than your tractor and extreme care must be taken to allow for safe clearance.



Be aware of physical surroundings and especially bystanders, particularly children, before moving the unit! This is particularly important with higher noise levels and quiet cabs, as you may not hear people shouting.

Never use independent braking with unit in tow as loss of control and/or upset of unit may result.

Always drive at a safe speed relative to local conditions, and ensure that your speed is low enough for an emergency stop to be safe and secure. Keep speed to a minimum.

Reduce speed prior to turns to avoid the risk of overturning.

Avoid sudden uphill turns on steep slopes.

Always keep the tractor or towing vehicle in gear to provide engine braking when going downhill. Do not coast.

Watch for overhead obstructions and side clearances while transporting.

Always operate equipment in a position to provide maximum visibility at all times. Make allowances for increased length and weight of the equipment when making turns, stopping, etc.

Safety Chain

SAFETY INSTRUCTIONS



Make sure the safety chain from the unit is securely fastened to the tow vehicle.

Always follow state and local regulations regarding a safety chain when towing farm equipment on a public highway.

Do not use any device other than an approved safety chain. Only a safety chain (not an elastic or nylon/plastic tow strap) should be used to retain the connection between the tow vehicle and the unit in the event of separation of the primary attaching system.

Highway and Transport Operations

SAFETY INSTRUCTIONS



Do not exceed a towing speed of more than 20 mph (32 KPH) on a public roadway. Tires supplied by the manufacturer are designed to operate NO MORE THAN 20 mph. Do not exceed the maximum speed or tire failure may occur.



When transporting the implement on public roads, use approved accessory lighting, flags, or other necessary warning devices to protect operators of other vehicles on the highway during daytime and nighttime transport. Various safety lights and devices are available from your dealer.



When towing the unit on public roads, use flashing amber warning lights and a slow moving vehicle (SMV) identification emblem.

Make sure the SMV placard is clearly visible to vehicles approaching from the rear.

Some localities prohibit the use of flashing amber lights. Local laws should be checked for all highway lighting and marking requirements.

Be a safe and courteous driver. Always yield to oncoming traffic in all situations, including narrow bridges, intersections, etc. Plan your route to avoid heavy traffic.

Be observant of bridge load restrictions. Do not cross bridges rated lower than the gross weight at which you are operating.

Make sure the wheel lift cylinder transport locks are installed, and the jack stand is in its storage position before transporting the unit.

When transporting the implement on rough or uneven surfaces, drive slowly to prevent bouncing and loss of contact of the front wheels and the ground .

OPERATION SAFETY



WARNING



Crush Hazard (Rolling Over)

Do not clean, lubricate, or make adjustments while the unit is moving .



Never allow inexperienced or untrained personnel to operate the implement or tractor without supervision .



Enter And Exit Tractor

To avoid being run over, do not enter or exit tractor when it is moving . Avoid serious injury or death, from contact with rotating tires, by entering or exiting tractor only when it is completely stopped .



Safe Distance

Keep all bystanders, especially children, away from the tractor and implement during operation .



Overturn Hazard

Pick the most level route possible when transporting across fields. Avoid the edges of ditches, gullies, or steep hillsides .

Be especially careful when turning on slopes with the wheels down . Never turn uphill with the wheels down except at slow speed and a low rate of turn .

Never transport or operate this machine on steep slopes

SAFETY INSTRUCTIONS



Periodically clear the unit of brush, twigs, or other materials to prevent buildup of dry, combustible materials .

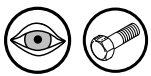

Visually check all fasteners for tightness or damage before and after operation . Repair immediately if required .

Tractor Requirements



WARNING



Tractor Owner/Operator Manual

Always refer to the tractor Operator's Manual to ensure compatibility and maximum safety.

Be familiar with the location, settings, and function of the tractor controls before using this equipment.

SAFETY INSTRUCTIONS

Do not use a tractor of more than the recommended HP to prevent damaging implement components.

Tractor Safety Devices

If transporting or operating the tractor and implement near a public roadway, the tractor must be equipped with proper warning lighting and a Slow Moving Vehicle (SMV) emblem, which are clearly visible from the rear of the unit. Lights and a SMV emblem must be attached directly to the implement if the visibility of the tractor warning signals is obscured.

Never operate the tractor PTO with the PTO master shield missing or in the raised position.

ROPS and Seat Belt

The tractor must be equipped with a Roll Over Protective Structure (ROPS) (tractor cab or roll-bar) and seat belt to protect the operator from falling off the tractor, especially during a roll-over where the driver could be crushed and killed. Only operate the tractor with the ROPS in the raised position and seat belt fastened.



WARNING



Rollover Hazard

To avoid serious injury or death from falling off tractor, equipment runover, rollover, or crushing:

- 1) Use ROPS equipped tractor.
- 2) Keep ROPS locked in the UP position .
- 3) Only operate the equipment when seated in the tractor seat .
- 4) Always fasten seat belt when operating the tractor and implement .

Attaching to Tractor

Prior to Connecting Unit

Make sure the unit is resting on the ground or the transport lock is securely installed over the wheel cylinder rod before attaching the unit to the tractor.

Connecting to Tractor



WARNING



Crush Hazard

Use care when attaching the unit to the tractor. Never place any part of your body under the tongue or hitch assembly . Do not allow anyone to stand between moving tractor and implement during hook-up operations.

Unexpected Separation Hazard



If towing the unit with a drawbar, use only a certified, hardened drawbar pin with a retainer clip. Do not use homemade pins, bolts, or any other type of retaining device. Always install the retainer clip, making sure the hitch and unit are securely fastened to the tow vehicle.

Using a pin not intended for this type of towing can result in unexpected separation of the unit from the tow vehicle, resulting in equipment damage and personal injury.

SAFETY INSTRUCTIONS

Connect implement hitch to the tractor properly.

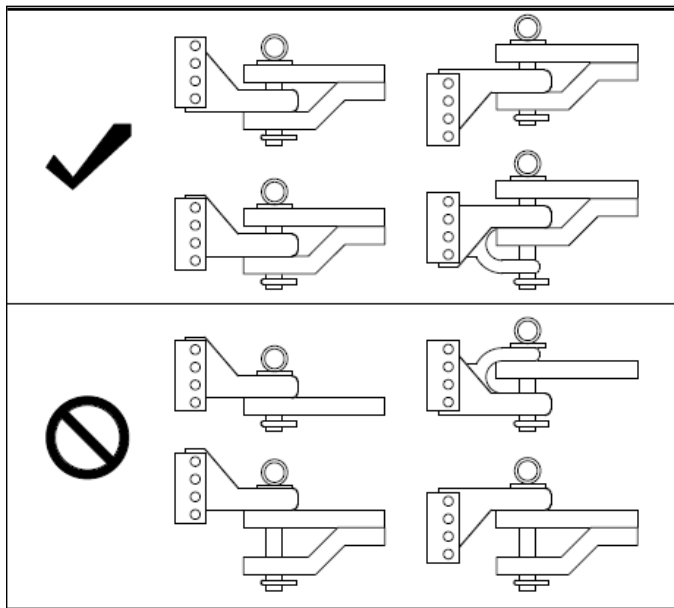

Hydraulic Component Safety

WARNING



High-Pressure Fluid Hazard

Before applying pressure to the system, make sure all components are tight and that the hydraulic lines, hoses, fittings, and couplings are not damaged.



Hydraulic Pressure

This unit operates with hydraulic pressures of 2500 to 3000 psi (170 to 205 bars).



Trapped Air Hazard

When installing, replacing, or repairing hydraulic system cylinders or parts, make sure that the entire system is charged and free of air before resuming operations. Failure to bleed the system of all air can result in improper machine operation, causing severe injury.

WARNING



High-Pressure Fluids

1. Check or tighten all connections BEFORE pressurizing system .
2. Release all pressure before removing hoses and/or valves by:
 - a. Stopping engine .
 - b. Holding hydraulic control levers in float or neutral position .
3. DO NOT use your bare hand to check for potential leaks . Always use a board or cardboard when checking for a leak .

Escaping hydraulic fluid under pressure, even a pinhole size leak, can penetrate body tissue, causing serious injury and possible death. If fluid is injected into your skin, it must be treated immediately by a doctor familiar with this type of injury.



Wear proper hand and eye protection when searching for a high-pressure hydraulic leak.

Use a piece of wood or cardboard as a backstop instead of hands to identify and isolate a leak .

If injured by a concentrated high-pressure stream of hydraulic fluid, seek medical attention immediately. Without immediate medical treatment, serious infection or toxic reaction can develop if hydraulic fluid penetrates the surface of the skin.



High-Pressure Separation Hazard

Replace any worn, cut, abraded, flattened, or crimped hoses .



Zero Pressure

Relieve pressure from the hydraulic system before servicing or disconnecting from the tractor.



High-Pressure Hazard

Do not make any temporary repairs to the hydraulic lines, fittings, or hoses using tape, clamps, or cement.

The hydraulic system operates under extremely high pressure and temporary repairs may fail suddenly and create a hazardous/ dangerous situation .

CAUTION



Explosive Separation Hazard

Be sure all hydraulic pressure is relieved before disconnecting hydraulic lines or fittings between implement and the tractor hydraulic system.

NOTICE

Make sure components in the hydraulic system are kept clean and in good working condition .

MAINTENANCE SAFETY



WARNING



Use Properly Rated Tools

Use sufficient tools, jacks, and hoists that have the capacity for the job.



Crush Hazard

Use support blocks or safety stands rated to support the load when performing maintenance.

SAFETY INSTRUCTIONS

Follow all operating, maintenance, and safety instructions found in this manual.



Understand the service procedure before performing the work. Keep area clean and dry.



Keep all parts in good condition and properly installed. Fix damage immediately. Replace worn or broken parts.



Do not leave tools lying on the unit.



Do not modify unit or safety devices. Do not weld on the unit. Unauthorized modifications may impair its function and safety.

If equipment has been altered in any way from the original design, the manufacturer does not accept any liability for injury or warranty.



Never replace hex bolts with less than Grade 5 bolts unless otherwise specified. In locations where Grade 8 bolts are used, Grade 8 replacements are required.



Where replacement parts are necessary for periodic maintenance and servicing, genuine factory replacement parts must be used to restore the unit to original specifications.

The manufacturer will not accept responsibility for damages as a result of the use of unapproved parts.

Tires Safety



WARNING



Explosive Separation Hazard

Do not attempt to mount a tire onto a wheel unless you have the proper equipment and experience to do the job. Failure to follow proper procedures when mounting a tire on a wheel can produce an explosive separation, which may result in serious injury or death.



Explosive Hazard

Never weld or heat a wheel and tire assembly. The heat can cause an increase in air pressure, resulting in a tire explosion. Welding can structurally weaken or deform the wheel.



Flying Objects Hazard

Inflating or servicing tires can be dangerous.

Whenever possible, trained personnel should be called to service and/or mount tires.

When inflating tires, use a clip-on chuck and extension hose. Always stand to the side of the tire when inflating, and NOT in front of or over the tire assembly. Make sure the tires are inflated evenly.

SAFETY INSTRUCTIONS



Always maintain the correct tire pressure. Do not inflate the tires above the recommended pressure.



Check tires for low pressure, cuts, bubbles, damaged rims, or missing lug bolts or nuts.



Keep wheel lug nuts or bolts tightened.



Always install replacement tires and wheels with appropriate capacity to meet or exceed the weight of the unit.

Bolt Torque Requirements

It is extremely important to apply and maintain proper torque on all bolts. Use a torque wrench to assure the proper amount of torque is being applied to the fastener.

Start all bolts or nuts by hand to prevent cross threading.

Torque figures indicated in the chart are used for non-greased or non-oiled threads unless otherwise specified.

Therefore, do not grease or oil bolts or cap screws unless otherwise specified in this manual. When using locking elements, increase torque values by 5%.

The chart gives correct torque values for various bolts and cap screws. Tighten all bolts to the torques specified in the chart unless otherwise noted. Check tightness of bolts periodically, using the bolt torque chart as a guide. Always replace hardware with the same Grade bolt.

WARNING



Equipment Failure

The torque value for bolts and cap screws are identified by their head markings. Replacing higher "Grade" bolts (Grade 5) with lower Grade bolts will lead to equipment failure and can result in injury or death. Always use replacement bolts with the same Grade markings as the removed bolt.

Bolt Diameter	Bolt Torque Specifications			
	Grade 5		Grade 8	
	N·m	ft.lbs.	N·m	ft.lbs.
1/4"	12	9	17	12
5/16"	25	19	36	27
3/8"	45	33	63	45
7/16"	72	53	100	75
1/2"	110	80	155	115
9/16"	155	115	220	165
5/8"	215	158	305	220
3/4"	390	290	540	398
7/8"	570	420	880	650
1"	850	630	1320	970

Tire and Lug Torque Specifications

Tire Size	Ply Rating	Lug Size	Lug Torque (lb.ft.)
7.6 x 15	8 Ply	1/2"	80
9.5 x 15	8 Ply	1/2"	80
12.5 x 16	14 Ply	9/16"	70

Welding Repairs



Before performing any type of welding repair to the implement, contact T.G. Schmeiser Co., Inc. for approval. Repair welding must be done with care and with procedures that may be beyond the capabilities of the ordinary welder.

WARNING



Personal Injury Hazard

Repairs or modifications to the implement can result in serious injury or death should these repairs fail.

NOTICE

Anyone performing a welding repair should be certified in accordance to the American Welding Society (AWS) standards.

STORAGE SAFETY

WARNING



Hazard And Information Signs

Replace any missing or hard-to-read safety signs. Safety sign placement and part numbers can be found in the Nomenclature section of this manual.



Damaged Parts Hazard

Do not use this unit if it is in need of repair. If you believe the unit has a defect which could cause damage, injury, or death, you should immediately stop using the unit.

SAFETY INSTRUCTIONS



Store the implement in an area away from human activity.



Do not permit children to play on or around the stored unit at any time.



Block the wheels to prevent the implement from rolling.



When using compressed air to clean implement, wear safety glasses.

SAFETY SIGNS AND DECALS

- It is the responsibility of the customer to know the marking requirements of the local highway authorities and to comply with the regulations.
- Keep safety signs clean and legible at all times. Replace safety signs that are missing or have become illegible.
- Do not paint over, remove, or deface any safety signs or instructional decals on your equipment. Observe all safety signs and follow the instructions on them.
- When parts that display a safety sign are replaced, the replacement part should display the same sign.
- Make sure the safety signs and other instructional decals are legible and attached to the unit before use.
- Safety signs are available from your Distributor, Dealer Parts Department, or the factory.
- Use care when washing or cleaning the unit not to remove or damage the labels.
- Locations for the labels and replacement part numbers are shown in this section.

Safety Sign Placement

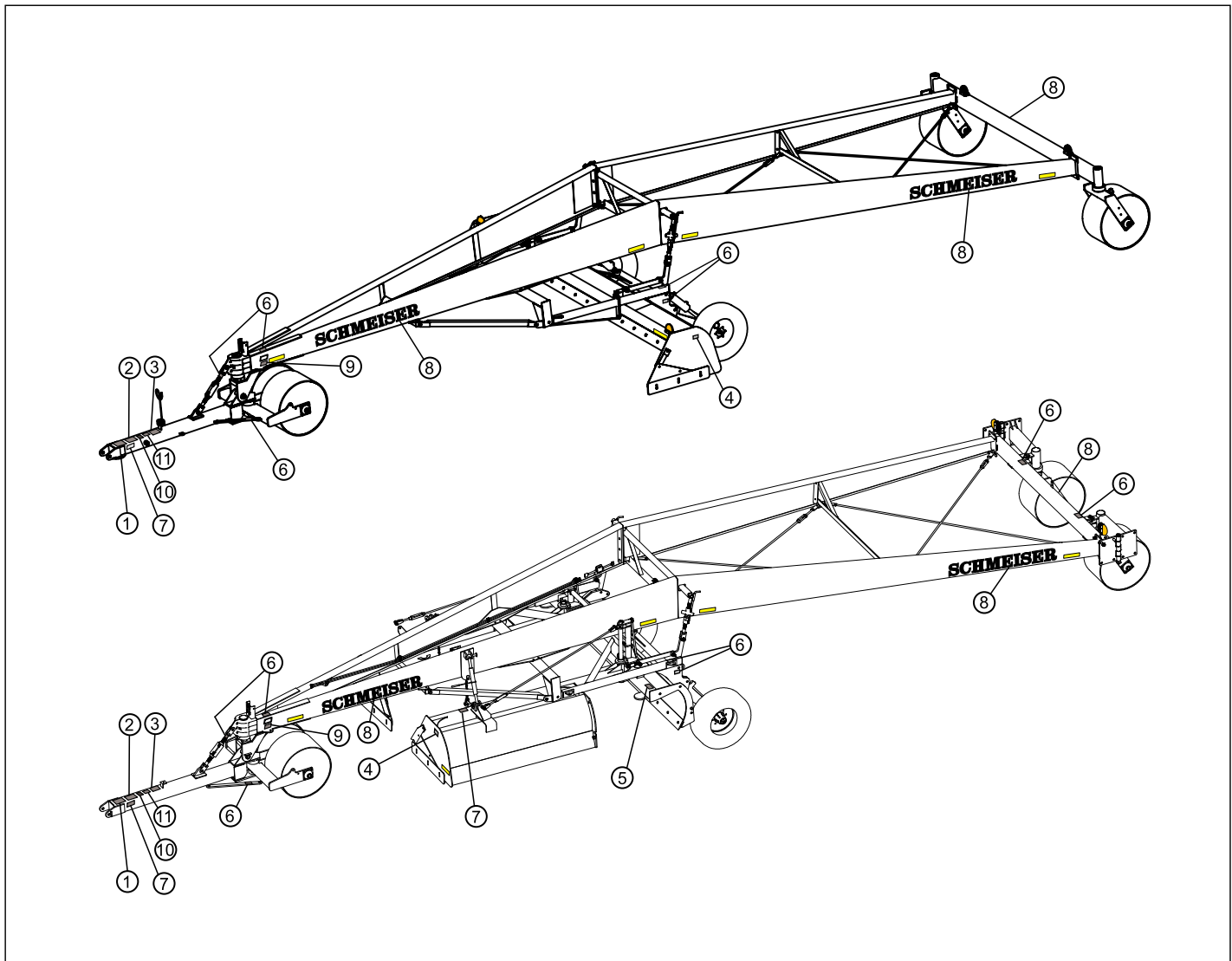

Safety Signs and Decals

Item	Part Number	Description	SLP	SLPF
1	D48X038RTM	Read the Manual	1	1
2	D48X038CRR	Crush / Rollover Hazard	1	1
3	D48X064HPF	High Pressure Fluids	1	1
4	D28X048SCE	Sharp Object Hazard	2	2
5	D28X048PPT	Pinch Point	—	2
6	D28X048RBW	Transport Lockout	7	9
7	D76X040SGB	Transport Safety Chain	1	3
8	D104608BLK	Schmeiser 6-1/2" X 38"	5	5
9	D32X048RBC	Made in the USA	1	1
10	D48X48QR	Scan to Access Online Manual	1	1
11	DFEMALOGO1	FEMA	1	1
12	D16X026GRS	Grease Decal	16	20
	D-KIT-SLP	Decal Kit for Rigid Tri Plane	1	—
	D-KIT-SLPF	Decal Kit for Folding Tri Plane	—	1

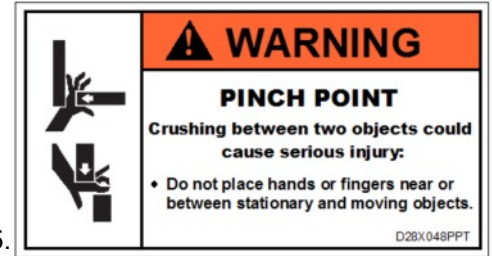

5.



6.



7.

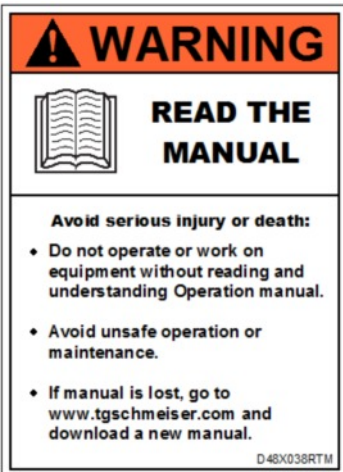

1.

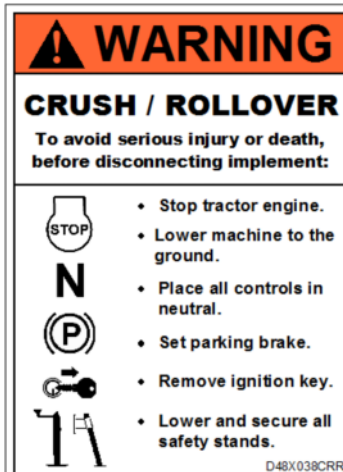

2.

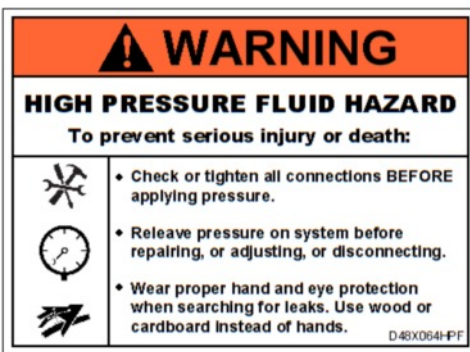

3.



8.



9.

D32X048



10.

D48X48QR



4.



11.



12.

SAFETY MARKING AND LIGHTING

Tri Plane - Rigid (12 Ft. to 18 Ft. Wide)

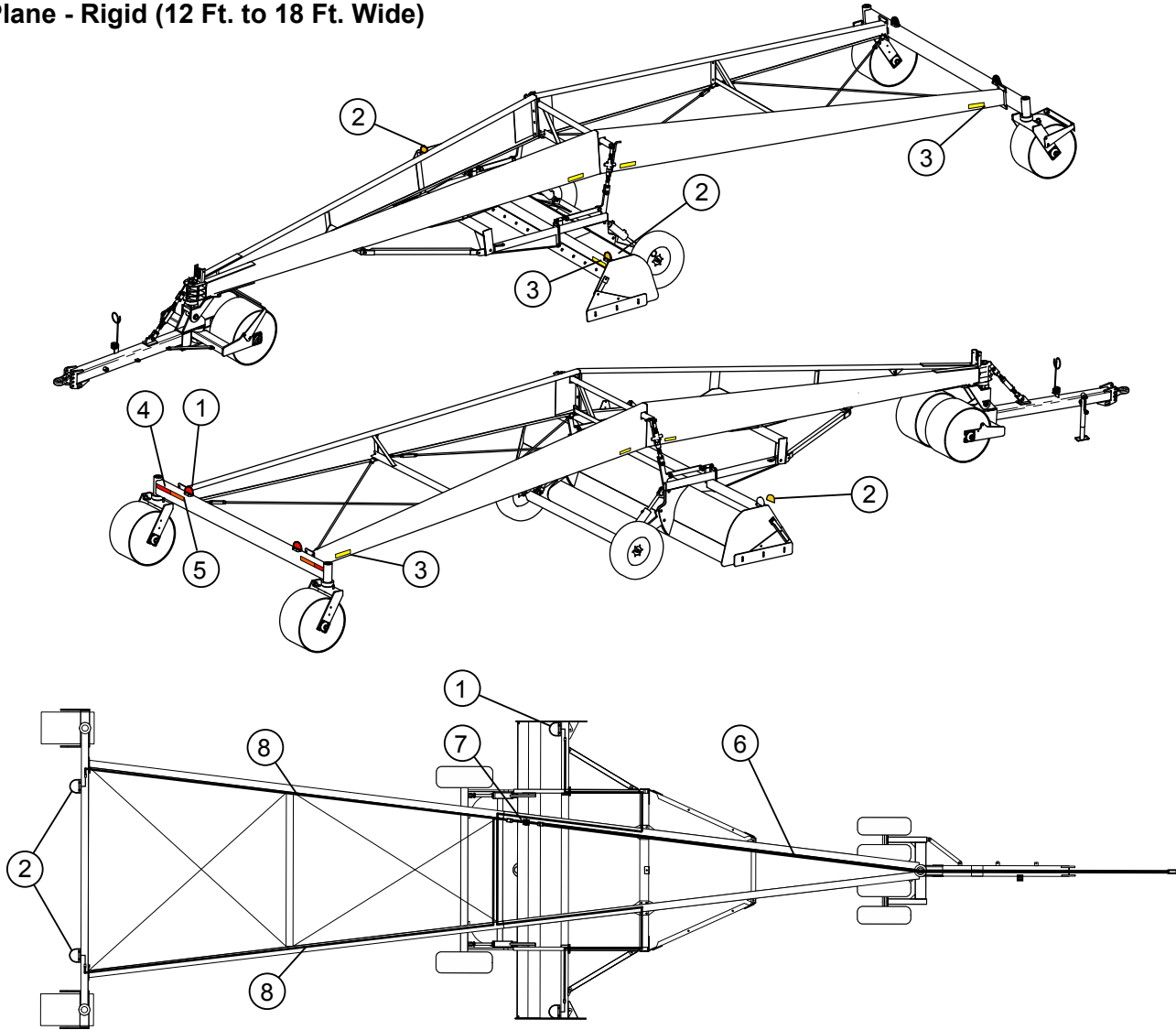

##	Part Number	Description	Q'ty
1	GLT-LSDY	Lamp, Surface Mount Double Yellow	2
2	GLT-LSSR	Lamp, Surface Mount Single Red	2
3	D-2X9RY	Reflective Tape, Yellow	10
4	D-2X9RR	Reflective Tape, Red	2
5	D-2X9FL	Fluorescent Tape, Orange	2
6	GLT-HF30	Front Harness, 30 Ft. Long	1
7	GLT-FCM	Flasher Control Module	1
8	GLT-HW5050	Rear Wishbone Harness 50 Ft.-50 Ft.	1

Tri Plane - Folding (20 Ft. to 24 Ft. Wide)

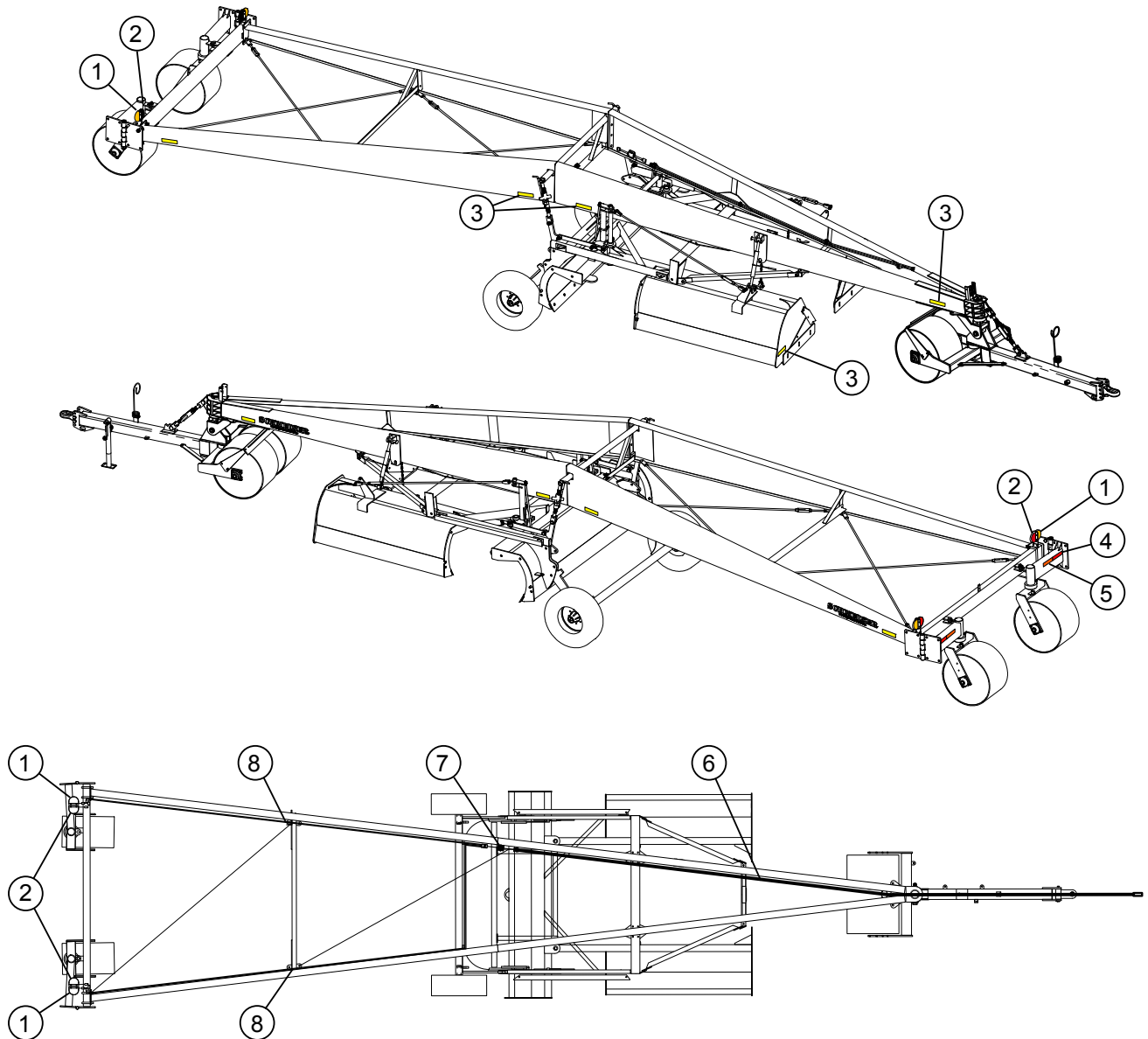

##	Part Number	Description	Q'ty
1	GLT-LSDY	Lamp, Surface Mount Double Yellow	2
2	GLT-LSSR	Lamp, Surface Mount Single Red	2
3	D-2X9RY	Reflective Tape, Yellow	10
4	D-2X9RR	Reflective Tape, Red	2
5	D-2X9FL	Fluorescent Tape, Orange	2
6	GLT-HF30	Front Harness, 30 Ft. Long	1
7	GLT-FCM	Flasher Control Module	1
8	GLT-HW5050	Rear Wishbone Harness 50 Ft.-50 Ft.	1

ASSEMBLY AND OPERATION



WARNING



Understand Safety Procedures!

Read and understand all safety procedures described in this manual before performing any work on or around the implement.

RIGID TRI PLANE ASSEMBLY PROCEDURE

THE FOLLOWING TOOLS ARE NEEDED:

- Truck with lifting boom, overhead hoist or forklift with 2000 pound lifting capacity.
- A 24" adjustable wrench or large pipe wrench.
- One 6" and two 12" adjustable wrenches.
- Socket wrench with 15/16" and 1-1/2" sockets.
- Heavy duty pliers.
- A heavy duty 12" screwdriver.
- A 14" tapered drift punch.
- A pry bar.
- A medium size ball peen hammer.
- A ten-pound sledge hammer.
- Grease gun.

PROCEDURE:

1. Place the main frame with the front bearing clamp toward the front on level ground. Raise front and put wooden block about 4" high underneath it. Place the left rear main frame butt to butt with the left front main frame. Join together. Line up the mating holes and install (2) 1-1/4" NC x 4-1/2" Gr.8 bolts with lock washers and hex nuts and (1) 5/8" NC x 2" bolt with lock washer and hex nut in the hole near the bottom 1-1/4" NC bolt. Do not tighten.

2. Hoist the center cross frame (see drawing on page 28 – item # 24) up with sling or chain attached to the 3" x 3" tube so that the cross frame is parallel to the ground and oriented to the square hole in the upper middle section of the left main frame. Line up the mating holes on the main frame and install (2) 1-1/4" NC x 4-1/2" Gr.8 bolts with lock washers and hex nuts and (1) 5/8" NC x 2" bolt

with lock washer and hex nut in the hole near the bottom 1-1/4" NC bolt. Make sure the cross frame is positioned so that the attaching bracket on the bottom side of the 3" x 3" square tube is flush on the side facing the forward end of the machine. Now slide the end of the square tube through the square hole in the frame until the two attaching holes match up. Install one 1" x 4" bolt with lock washer and hex nut and one 1" x 3" bolt with lock washer and hex nuts. Do not tighten. Keep center cross frame suspended.

3. Place the right rear main frame butt to butt with the right front main frame. Join together. Be sure that the end of the center cross frame square tube goes through the square hole in the right side of the main frame until the two attaching holes match up. Install one 1" x 4" bolt with lock washer and hex nut and one 1" x 3" bolt with lock washer and hex nuts. . Line up the mating holes on the main frame and install (2) 1-1/4" NC x 4-1/2" Gr. 8 bolts with lock washers and hex nuts and (1) 5/8" NC x 2" bolt with lock washer and hex nut in the hole near the bottom 1-1/4" NC bolt. Do not tighten.

4. Install rear inside frame (see drawing on page 28 – item # 27). Use (4) 5/8" NC x 2" bolts, lock washers and hex nuts. Tighten all bolts securely.

5. Lift up front of the machine. Open up front clamp BC-200 and install the front steel wheel frame and main frame pivot shaft assembly (with bearing housing, thrust bearing, inner races, pin bearings, shaft cap, oil seal & dust cap) into the bearing clamp opening on the front end of the right and left main frames. Join the bearing clamps together and line up the six mating holes. Install six 3/4" NC x 2" bolts, lock washers and hex nuts.

Tighten up enough to hold bearing housing in place. See page 32 for details.

6. Install front pivot shaft lockout (with two slotted holes). See drawing on page 32 - item # 21. Use two 3/4"NC x 2" bolts, flat washers, lock washers and hex nuts. Tighten securely. Place lock pin in position.

7. Position rear cross frame with attached steel wheels against the mounting plates on the rear end of the main frame. Guide stops on the rear cross frame should be next to mounting plates on the main frame. Adjust main frame height (if necessary) so that the two 8" U-bolts (see drawing on page 28 – item # 34) can be placed around the rear cross frame tube and inserted through the four mating holes in the end plate of the rear main frame. Install four 7/8" NF hex nuts and lock washers.

Make necessary sideways adjustments and tighten securely.

8. Put bucket with attached bucket arms beside main frame with pull arms facing forward. Place piece of pipe underneath bucket. Push bucket from one end under main frame until bucket arms align with bucket cross brace. Fasten with 1" x 4" bolts and nylon lock nuts. Do not tighten.

9. Mount top turnbuckle stub (see drawing on page 35 – item # 7) to center cross frame using 1/2" x 1-1/2" bolt with lock washer and turnbuckle end plate. Tighten securely.

10. Screw turnbuckle body (see drawing on page 35 – item # 5) onto top stub leaving 4" of thread showing. Screw in lower turnbuckle stub (see drawing on page 35 – item # 4). Leave about 4" of thread showing.

11. Attach longer end of T-Bar link (see drawing on page 35 – item # 3) to lower turnbuckle stub using 1" x 3-1/2" bolt with zerk fitting and secure with 1" nylon lock nut.

12. Install adjustment rod (see drawing on page 35 – item # 1) on the bucket using (2) 1" jam hex nuts.

13. Mount one end of straight link (see drawing on page 35 – item # 2) to adjustment rod using 1" x 3" bolts with lock washers and hex nuts. Do not tighten.

14. Connect top hole of bucket axle clevis plate with bottom hole of T-Bar link using 1" x 6-1/2" bolt with zerk fitting and secure with 1" nylon lock nut. Line up other end of straight link with the T-bar link end hole. Lift front section of the machine from under main frame until bucket turnbuckle is in vertical position and the mating holes line up. Install 1" NC x 3" bolt with zerk fitting; then install 1" nylon lock nut. Make sure the grease fitting is facing out. See page 35 for details.

15. Tighten adjustment rod jam nuts and 1" hex nut. Make sure that all bolts with nylon lock nuts are secure but able to move.

16. Repeat same procedure for the other side.

17. Push the tire axle (see drawing on page 28 – item # 19) under the main frame. Align the tire axle so that when mounted to the rear of the bucket, the cylinder anchors are on the backside toward the rear cross frame. Now push the tire axle up until the legs slide into the gussets on the rear of the bucket. Line up the holes

and insert a 1" NC x 3-1/2" bolt with zerks, through each hole. Install a nylon lock nut on each bolt and tighten.

18. Install hydraulic steel tubes along L.H. side of Top Frame. Secure with double hycon clamps.

19. Attach 3" x 8" welded hydraulic cylinders (see drawing on page 28 – item # 23) with rod ends facing away from bucket to the tire axle.

20. Install hydraulic hoses according to hydraulic diagram on page 46. Use thread sealant on all pipe and hose joints. Support the piping with hycon clamps. Use five 5/16" NC x 2-1/2" bolts, lock washers and hex nuts.

21. Install two short cross rods between the center cross frame and the rear inside frame. Use two 5/8" NC x 2" bolts, lock washers and hex nuts at center cross frame and two 5/8" NC x 2" bolts, lock washers and hex nuts at the rear inside frame end. Leave the rod assemblies loose.

22. Now install the two long cross rods between the rear inside frame and the rear cross frame. Use two 5/8" NC x 2" bolts, lock washers and hex nuts at the rear end of the main frame and two 5/8" NC x 2" bolts, lock washers and hex nuts at the rear inside frame end. Leave the rod assemblies loose.

23. Tighten up all eight cross rod attaching bolts.

24. Tighten up all four cross rod turnbuckles sufficiently to square up the frames. Install the cross rod U-bolts (see drawing on page 28 - item # 35).

25. Make a final check of the assembled Land Leveler. Cross rods should be tightened. The jam nut should be locked up against the turnbuckle. The front turnbuckle must be adjusted correctly. Lock pins should be in place. Make sure all frame and cross member bolts are tight. 8" U-bolts must be tight and positioned correctly on the rear cross frame. Grease all zerk fittings prior to operation.

FOLDING TRI PLANE ASSEMBLY PROCEDURE

THE FOLLOWING TOOLS ARE NEEDED:

- Truck with lifting boom, overhead hoist or forklift with 2000 pound lifting capacity.
- A 24" adjustable wrench or large pipe wrench.
- One 6" and two 12" adjustable wrenches.
- Socket wrench with 15/16" and 1-1/2" sockets.
- Heavy duty pliers.
- A heavy duty 12" screwdriver.
- A 14" tapered drift punch.
- A pry bar.
- A medium size ballpeen hammer.
- A ten-pound sledge hammer.
- Grease gun.

PROCEDURE:

1. Place the main frame with the front bearing clamp toward the front on level ground. Raise front and put wooden block about 4" high underneath it. Place the left rear main frame butt to butt with the left front main frame. Join together. Line up the mating holes and install (2) 1-1/4" NC x 4-1/2" Gr.8 bolts with lock washers and hex nuts and (1) 5/8" NC x 2" bolt with lock washer and hex nut in the hole near the bottom 1-1/4" NC bolt. Do not tighten.

2. Hoist the center cross frame (see drawing on page 29 – item # 24) up with sling or chain attached to the 3" x 3" tube so that the cross frame is parallel to the ground and oriented to the square hole in the upper middle section of the left main frame. Line up the mating holes on the main frame and install

(2) 1-1/4" NC x 4-1/2" Gr.8 bolts with lock washers and hex nuts and (1) 5/8" NC x 2" bolt with lock washer and hex nut in the hole near the bottom 1-1/4" NC bolt. Make sure the cross frame is positioned so that the attaching bracket on the bottom side of the 3" x 3" square tube is flush on the side facing the forward end of the machine. Now slide the end of the square tube through the square hole in the frame until the two attaching holes match up. Install one 1" x 4" bolt with lock washer and hex nut and

one 1" x 3" bolt with lock washer and hex nuts. Do not tighten. Keep center cross frame suspended.

3. Place the right rear main frame butt to butt with the right front main frame. Join together. Be sure that the end of the center cross frame square tube goes through the square hole in the right side of the main frame until the two attaching holes match up. Install one 1" x 4" bolt with lock washer and hex nut and one 1" x 3" bolt with lock washer and hex nuts. . Line up the mating holes on the main frame and install (2) 1-1/4" NC x 4-1/2" Gr.8 bolts with lock washers and hex nuts and (1) 5/8" NC x 2" bolt with lock washer and hex nut in the hole near the bottom 1-1/4" NC bolt. Do not tighten.

4. Install rear inside frame (see drawing on page 29 – item # 27). Use (4) 5/8" NC x 2" bolts, lock washers and hex nuts. Tighten all bolts securely.

5. Lift up front of the machine. Open up front clamp BC-200 and install the front steel wheel frame and main frame pivot shaft assembly (with bearing housing, thrust bearing, inner races, pin bearings, shaft cap, oil seal & dust cap) into the bearing clamp opening on the front end of the right and left main frames. Join the bearing clamps together and line up the six mating holes. Install six 3/4" NC x 2" bolts, lock washers and hex nuts. Tighten up enough to hold bearing housing in place. See page 32 for details.

6. Install front pivot shaft lockout (with two slotted holes). See drawing on page 32 - item # 21. Use two 3/4" NC x 2" bolts, flat washers, lock washers and hex nuts. Tighten securely. Place lock pin in position.

7. Position rear cross frame against the mounting plates on the rear end of the main frame (see page 29 - item # 30). Guide stops on the rear cross frame should be next to mounting plates on the main frame. Adjust main frame height (if necessary) so that the two 8" U-bolts (see drawing on page 29 – item # 34) can be placed around the rear cross frame tube and inserted through the four mating holes in the end plate of the rear main frame. Install four 7/8" NF hex nuts and lock washers. Make necessary sideways adjustments and tighten securely.

8. Attach rear steel wheel pivot frames to the rear cross frame (see page 29 - item # 31). Use 1-1/2" Rear Hinge Pins with slotted hex nuts and cotter pins. Mount steel wheels to the pivot frames (see page 44 for details).

9. Put bucket beside main frame with pull arms facing forward. Place piece of pipe underneath bucket. Push bucket from one end under main frame until bucket arms align with bucket cross brace. Fasten with 1" x 4" bolts and nylon lock nuts. Do not tighten.
10. Mount top turnbuckle stub (see drawing on page 35 – item # 7) to center cross frame using 1/2" x 1-1/2" bolt with lock washer and turnbuckle end plate. Tighten securely.
11. Screw turnbuckle body (see drawing on page 35 – item # 5) onto top stub leaving 4" of thread showing. Screw in lower turnbuckle stub (see drawing on page 35 – item # 4). Leave about 4" of thread showing.
12. Mount wings to both sides of main frame bucket. Use 2-1/4" dia. Hinge Pin. Secure it in place with 3/8" X 4" NC Gr.5 Cap Screw, lock washer, and hex nut. Ensure that main frame bucket and wing buckets are lined up (see drawing on page 39).
13. Install truss rod mast frames (see page 39 - item # 38). Center them and mount to the main frame using 3/4" x 2-1/2" NC Cap Screw with lock washers and hex nuts. Ensure that the hinge pin is secured with 3/8" x 3" NC Gr.5 Cap Screw with lock washers and hex nuts on top of the masts and the truss rod pivot bushings are in place before mounting truss rods (see drawing on page 39).
14. Mount cross brace to the truss rod mast frames using 5/8" U-Bolts with lock washers and hex nuts.
15. Mount long truss rod ends to the truss rod pivot bushings and short ends to the wing truss rod anchors. Adjust truss rod length to level wing buckets with main frame bucket.
16. Attach one of the ends of the top link ratchet (see drawing on page 41 – item # 6) to the main frame lockout ears using 1" x 4-1/2" bolt and secure with 1" lock washer and hex nut.
17. Fold the wing and place the other end of the top link ratchet between the lockout plates on the wing. Secure with 1" x 4-1/2" lockout pin and lynch pin (adjust ratchet length if needed). Tighten the top link ratchet for transport to eliminate any wing bucket movement (see drawing on page 45 - item # 6).
18. Repeat same procedure for the other side.
19. Push the tire axle (see drawing on page 29 – item # 19) under the main frame. Align the tire axle so that when mounted to the rear of the bucket, the cylinder anchors are on the backside toward the rear cross frame. Now push the tire axle up until the legs slide into the gussets on the rear of the bucket. Line up the holes and insert a 1" NC x 3-1/2" bolt with zerks, through each hole. Install a nylon lock nut on each bolt and tighten.
20. Install hydraulic steel tubes along L.H. side of Top Frame. Secure with double hycon clamps.
21. Attach 3" x 8" welded hydraulic cylinders (see drawing on page 29 – item # 23) with rod ends facing away from bucket to the tire axle.
22. Install hydraulic hoses according to hydraulic diagram on page 46. Use thread sealant on all pipe and hose joints. Support the piping with hycon clamps. Use five 5/16" NC x 2-1/2" bolts, lock washers and hex nuts.
23. Install two short cross rods between the center cross frame and the rear inside frame. Use two 5/8" NC x 2" bolts, lock washers and hex nuts at center cross frame and two 5/8" NC x 2" bolts, lock washers and hex nuts at the rear inside frame end. Leave the rod assemblies loose.
24. Now install the two long cross rods between the rear inside frame and the rear cross frame. Use two 5/8" NC x 2" bolts, lock washers and hex nuts at the rear end of the main frame and two 5/8" NC x 2" bolts, lock washers and hex nuts at the rear inside frame end. Leave the rod assemblies loose.
25. Tighten up all eight cross rod attaching bolts.
26. Tighten up all four cross rod turnbuckles sufficiently to square up the frames. Install the cross rod U-bolts (see drawing on page 29 – item # 36).
27. Make a final check of the assembled Land Leveler. Cross rods should be tightened. The jam nut should be locked up against the turnbuckle. The front turnbuckle must be adjusted correctly. Lock pins should be in place. Make sure all frame and cross member bolts are tight. 8" U-bolts must be tight and positioned correctly on the rear cross frame. Grease all zerk fittings prior to operation.

TO TRANSPORT TRI PLANE ON THE ROAD:

1. Move the bucket to its lowest position and install the cylinder locking bars. The tire axle will be up and lock pins in place. Remove both lock pins from the tire axle. Lower the tire axle hydraulically until the lock pins can be reinserted into the same holes. This will lock the wheels into the transport position with the rear steel wheels off the ground.

2. Fold wing buckets (*Folding Tri Plane only*) forward and pin in place with red lockout pins provided. Tighten top link ratchets to eliminate any wing movement. Secure wings to the main frame using safety chains with hooks.

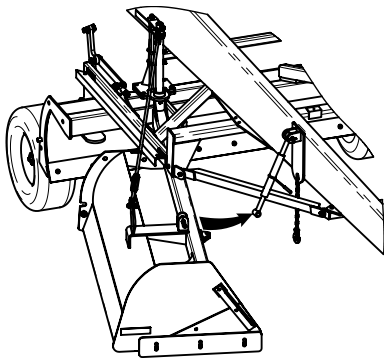

3. Fold rear steel wheel pivot frames (*Folding Tri Plane only*) back and pin in place with lockout pins provided.

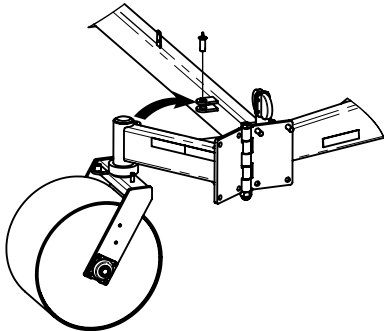

4. Adjust the front turnbuckle to hookup to the tractor drawbar, and then readjust for the wheel/ground clearance desired.

5. Align the tongue with the frame center line; insert the pivot shaft lockout pin, with the wrench portion up, between the frames and through the rear hole of the front main frame pivot shaft.

6. Do not try to move the Land Leveler on the road on its steel wheels. Always use the transport wheels when moving on roadways.

TO LOWER LAND LEVELER FOR LAND LEVELING:

1. Lower the tire axle hydraulically enough to remove the locking pins. Raise the tire axle slowly until the front or rear wheels touch the ground. Adjust the front turnbuckle until the pins are free. Remove turnbuckle top pin and swing turnbuckle forward into storage position.

2. If the machine does not have a hydraulically actuated bucket, lift arm locks must be used on each side.

3. Remove the pivot shaft lockout pin, the 1" shaft between the front ends of the frame; place it in the pin holder bracket at the front of the machine.

4. The bucket leveling and depth adjustments are made by adjusting the lift screws located on each side of the Land Leveler.

5. Unfold rear steel wheel frames (*Folding Tri Plane only*) and secure them in place with 1" X 3-1/2" cap screws with lock washers and hex nuts.

6. Loosen wing lockout ratchets (*Folding Tri Plane only*) to remove lockout pins and unfold wings. Adjust truss rod lengths if needed. Fasten wings to the main frame bucket mating plates with 1" x 2-1/2" cap screws with lock washers and hex nuts.

7. Check the rear wheels for travel alignment:

- Loosen both stabilizer bearing cap screws to assure that the bearing or roller is free to move in the slot.
- Stretch a string from the outside of one wheel rim to the outside of the opposite wheel rim approximately 14" off of and parallel to the ground.
- Adjust each wheel so that the string touches the full surface of each wheel rim with no bend in the string. (Visually check from outside of one wheel to the outside of the other)
- Retighten the bearing or roller cap screws in the stabilizer.
- Remove the string and now the Land Leveler is ready to use.

6. Operating the machine under adverse conditions, such as extremely rough ground, rocks or stumps, may cause the hitch end bolt to break. If this occurs, do not replace the factory installed bolt with a case hardened bolt. It is intended to be a safety shear pin.

7. Adjust the bucket lift turnbuckle to "Level", set blade and working height of the bucket.

8. Recheck adjustment No. 7 above, to make sure pivot point is within tolerance (0" to 1/8"). If necessary, readjust No. 7 above.

HYDRAULIC BUCKET OPTION

Adjust cylinder adjusting screw, located on the piston end of the bucket cylinder, so that the pivot point (A) is located 1/8" forward of a direct line between the upper turnbuckle; attach point (B) and the lower attach point (C) on each side of the machine. (See Drawing on the right)

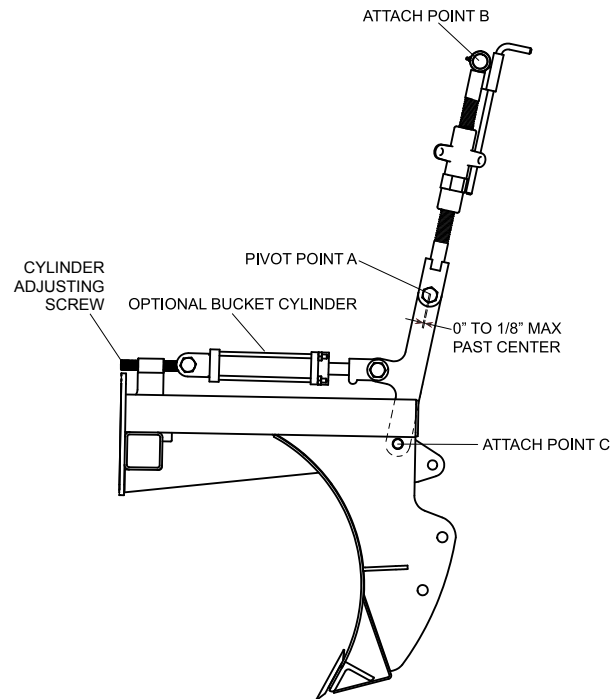

Hydraulic Bucket Option Hydraulic Diagram

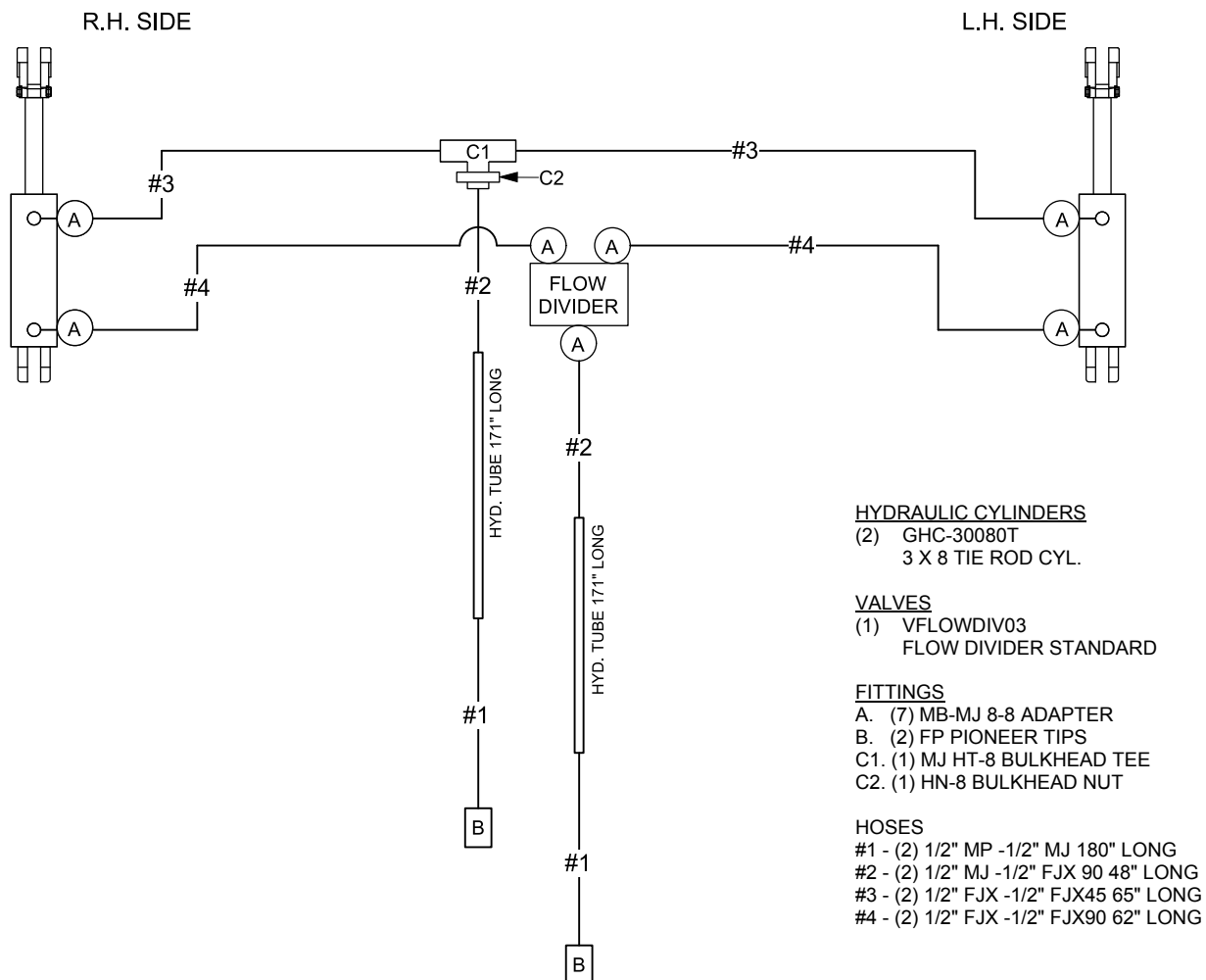

MAINTENANCE



WARNING



Understand Safety Procedures!

Read and understand all safety procedures described in this manual before performing any work on or around the implement.

Lubrication Points

Add grease to the locations shown.

Wheel Hub Bearings

Grease once per season – inspect bearings and races for wear and replace if necessary.

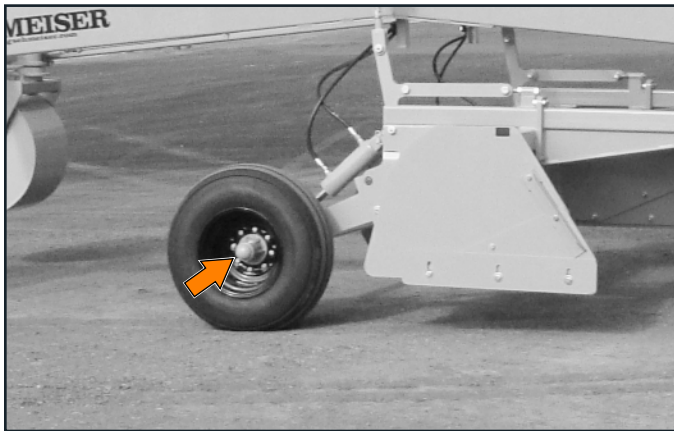

Turnbuckles and Linkage

Grease once per season.

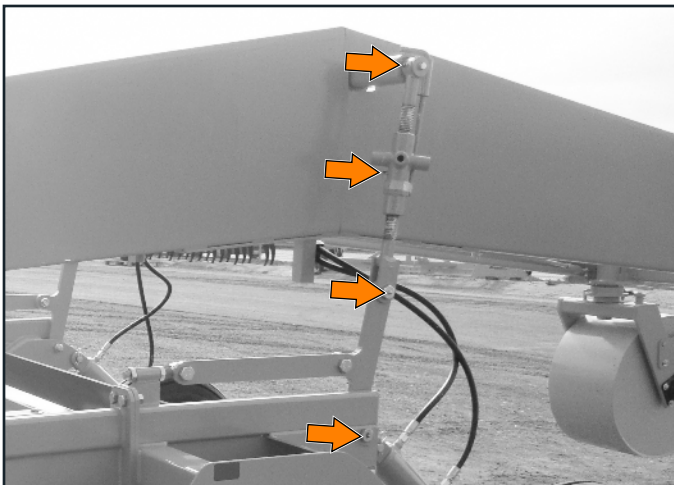

Ground Engaging Components

Ground engaging components are subject to abrasion and wear. Excessively worn components will require replacement.

Bucket Blades

Replace blade if it's excessively worn or damaged.

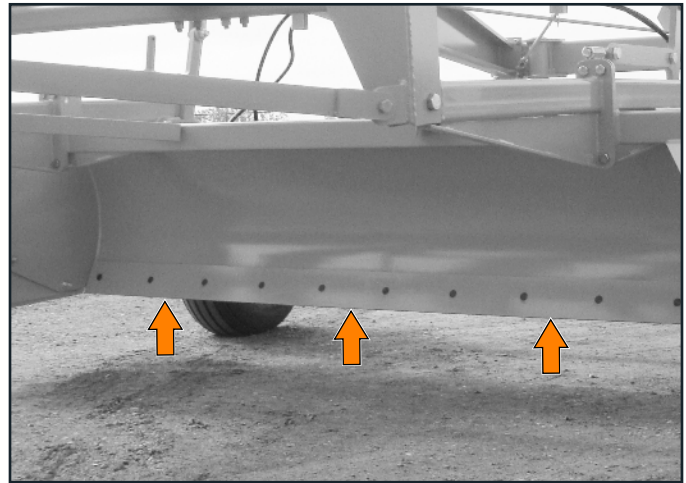

Adjustable Side Blades

The slotted mounting holes provide 2" of adjustment, which may be used to compensate for wear. Blades can be removed, turned over, and reattached to present a fresh edge. Replace the blades when both sides are worn out.

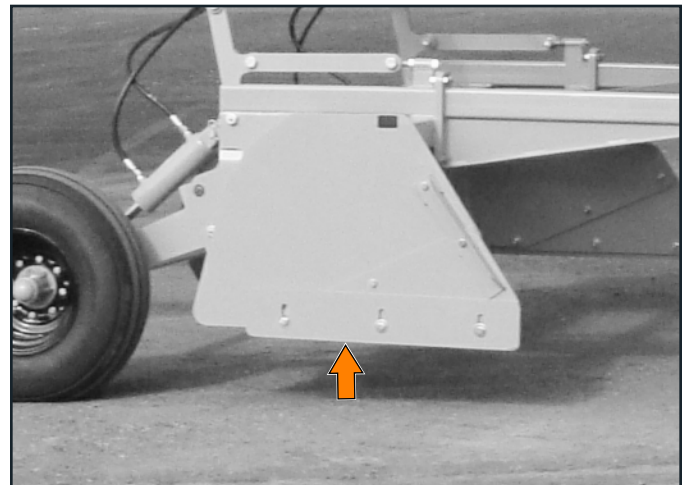

STORAGE

Storage Preparation

After Trii Plane field work is completed for a season, perform the following maintenance procedures before storing the implement.

1. Check all bolted connections. Ensure that the fasteners are tight, and all retaining pins are secured in place with appropriate retaining clips.
2. Check the tire pressure and set to the tire manufacturer's recommended specification. Inspect the tires for wear and/or damage. Make sure the wheel lugs are properly tightened. Refer to "Tire and Lug Torque Specifications" on page 13.
3. Inspect the frame for structure fractures and inspect the blades for wear or damage.
4. Check hubs for signs of seal damage or excessive wear.
5. Inspect all the hydraulic hoses and fittings for leaks or signs of wear.
6. Make sure all the warning decals are in place and legible. Replace any worn decals as needed.
7. Remove debris and clean the entire implement with compressed air or low pressure water.
8. Lubricate all grease fittings on the frame members with a good general purpose lithium grease. Refer to "Lubrication Points" on page 24 for the location of the fittings.
9. Add grease to the fittings on the transport wheel bearing hubs with a good quality wheel bearing grease. Fill each cavity just until resistance is felt. Do not force grease past the seals.
10. Apply a thin layer of grease or rust preventative to all exposed metal surfaces of the cylinder rods.
11. To help prevent corrosion, remove rust and apply a coat of paint to frame surfaces where paint has been worn off or damaged.

Placing in storage

1. Raise the implement, place jack stand in the transport mode, and install the transport lock on hydraulic cylinder.
2. Move the Tri Plane to a storage area with a firm and level base to prevent it from tipping or sinking into the ground. Always store the Tri Plane in a dry, protected location. Leaving this implement unprotected will shorten the service life.
3. Disconnect all hydraulic hoses, and unhitch the implement from the tractor.
4. Store the implement with the transport wheels extended in the transport mode and the wheel axle locking pins installed in locking position. Do not leave the tractor attached to the implement while in storage.

Removing From Storage

Each season, perform the following inspection and maintenance before using the unit.

1. Read the operator's manual to review all safety, operational, and maintenance procedures.

Note: Store the operator's manual in the document storage canister located on the main frame.





2. Perform any recommended maintenance that was not completed when the implement was put into storage.
3. Visually inspect the implement for wear or damage.
4. Check the tire pressure and set to the tire manufacturer's recommended specification. Inspect the tires for wear and/or damage.
5. Inspect all the hydraulic hoses and fittings for leaks and signs of wear or damage.
6. Make sure all the warning decals are in place and legible. Replace any damaged or missing decals.
7. Hitch the implement to a tractor and connect all hydraulic hoses. Refer to hydraulic diagram on page 46 for proper connections. Place the implement in an area clear of overhead obstructions or power lines. Cycle the hydraulic system circuit to engage hydraulic cylinders, verify proper operation, and check for leaks.

DISPOSAL OF EQUIPMENT AT END OF USEFUL LIFE

The T. G. Schmeiser implement has been designed for the specific purpose of conditioning the ground in agricultural applications. When this unit is no longer capable of doing its designed purpose, it should be dismantled and scrapped. Do not use any materials or components from this unit for any other purpose.

COMPONENT NOMENCLATURE

Rigid Tri Plane

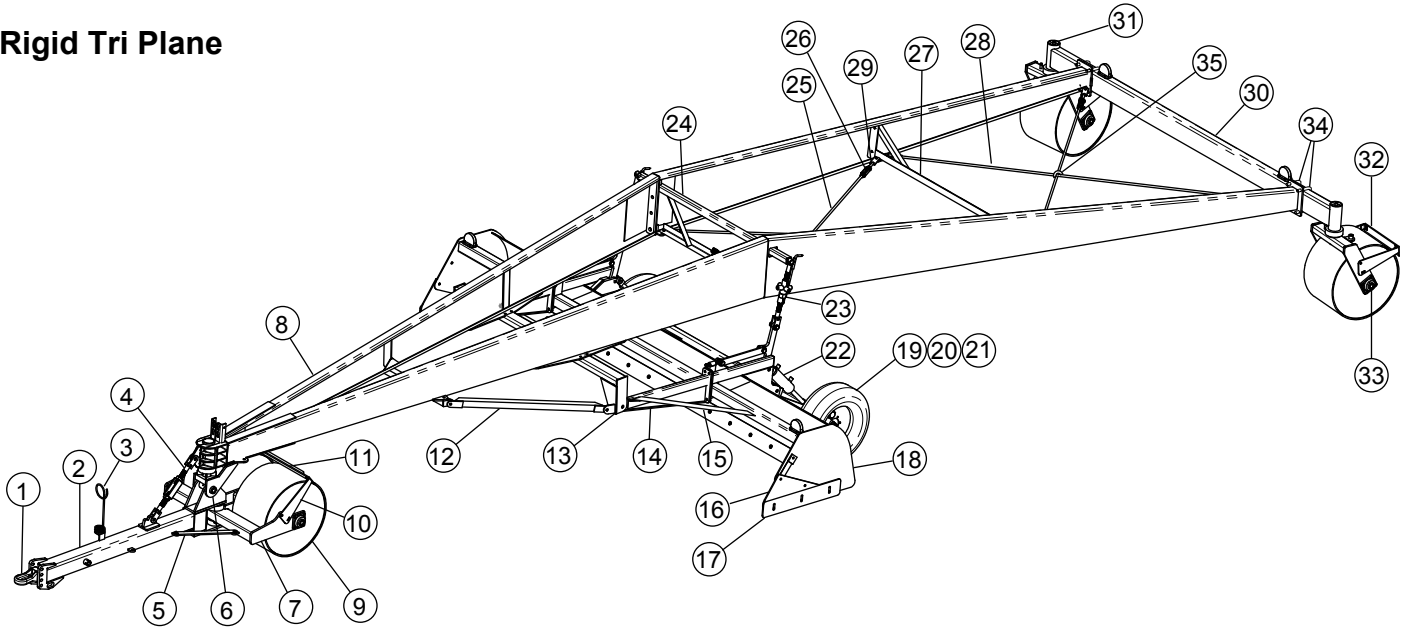

Item	Part #	Description	40'	30'
1	GMB-HITCHCA3H	Perfect Hitch CA 3 Heavy	1	1
2	SLP-00Q000	Tongue	1	1
3	GHD-HHOLD1	Hydraulic Line Support	1	1
4	SLP-00Q300	Front Turnbuckle Assembly	1	1
5	SLP-00Q118	PF Lockout Plate	1	1
6	SLP-00N200	Main Frame Pivot Shaft	1	1
7	SLP-00P100	Front Steel Wheel Frame	1	1
	SLP-00P400	Quad Tire Frame (Optional)	1	1
8	SLP-00A000	Main Frame	1	1
9	SLP-00D000	Steel Wheel	4	4
10	SLP-00B200L	Scraper Blade Arm LH	3	3
	SLP-00B200R	Scraper Blade Arm RH	3	3
11	SLP-00P200	Front Scraper Blade	1	1
12	SLP-00J200	Pull Brace	2	2
13	SLP-00J100	Cross Brace - T.F. to Bucket	1	1
14	SLP-00K000	Bucket Pull Arm	2	2
15	SLP-00K007R	Pull Arm Tie Bar R.H. (specify size)	1	1
	SLP-00K007L	Pull Arm Tie Bar L.H. (specify size)	1	1
16	SLP-00L200R	Bucket Side R.H.	1	1
	SLP-00L200L	Bucket Side L.H.	1	1

Item	Part #	Description	40'	30'
17	SLP-00L104	Side Bucket Adjustable Blade	2	2
18	SLP-00L100	Tri Plane Rigid Bucket (specify size)	1	1
19	SLP-00H000	Tri Plane Tire Axle	1	1
20	GWT-951508	9.5 X 15 8 Ply Tire / Wheel Assy	1	1
21	GHB-8X8HVY	8 X 8 Heavy Hub	2	2
22	GHC-35080WB	3.5 X 8 Welded Hyd. Cylinder	2	2
23	SLP-MTB	Bucket Turnbuckle Assembly	2	2
24	SLP-00F000	Center Cross Frame	1	1
25	SLP-00A400	Front Rod - 114"	2	2
26	GTB-12X96A	3/4" X 6" Turnbuckle Assembly	4	2
27	SLP-40G000	Rear Inside Frame- For 40' Units	1	0
28	SLP-00A500	Rear Rod - 126" - For 40' Units	2	0
29	SLP-00A300	L.H. Thread Stub End	4	2
30	SLP-14C100	Rear Cross Frame For 12' & 14'	1	1
	SLP-16C100	Rear Cross Frame For 16' & 18'	1	1
31	SLP-00B100	Rear Steel Wheel Frame	2	2
32	SLP-00B203	Scraper Blade - Rear	2	2
33	TPP3152	1-11/16" Flange Bearing	8	8
34	JBNF14128S	Rear Frame 8" Square U-Bolt	4	4
35	JBNC05X22P	5/16" X 1-3/8" U-Bolt	2	1

Folding Tri Plane

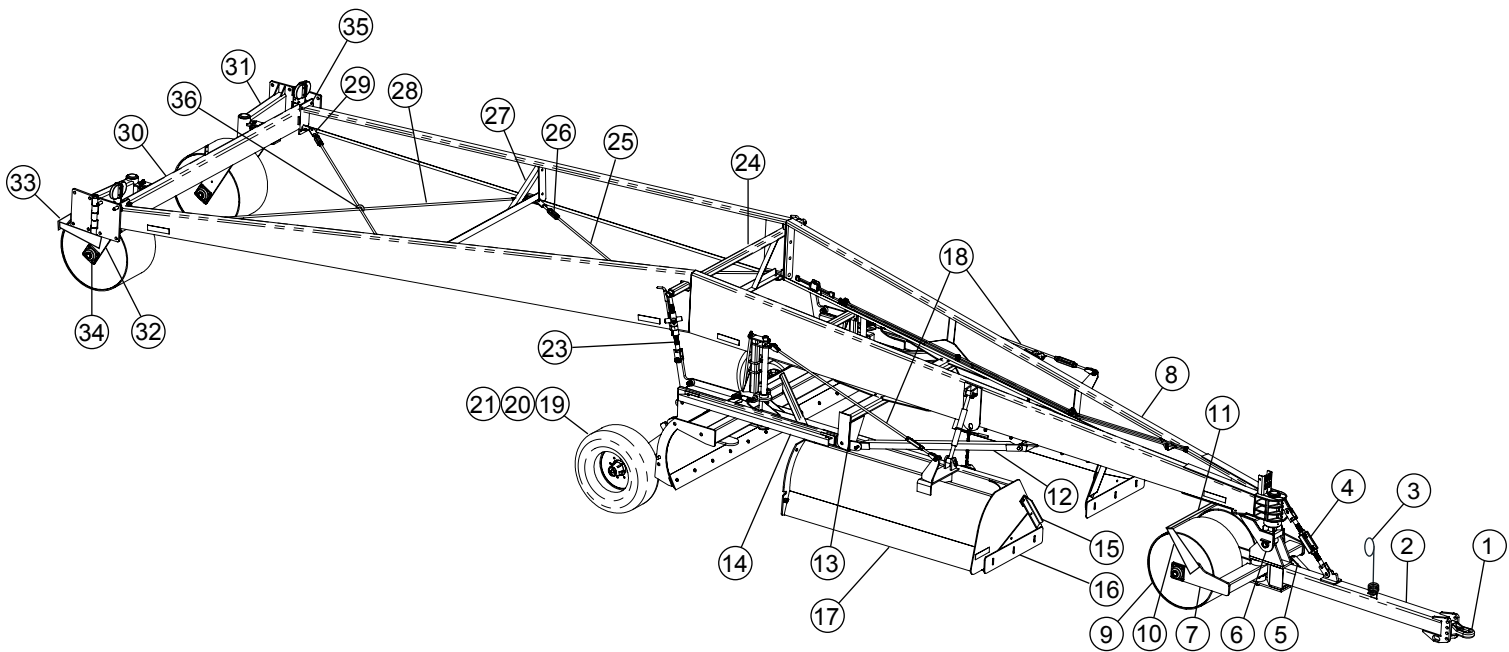

Item	Part #	Description	40'	30'
1	GMB-HITCHCA3H	Perfect Hitch CA 3 Heavy	1	1
2	SLP-00Q000	Tongue	1	1
3	GHD-HHOLD1	Hydraulic Line Support	1	1
4	SLP-00Q300	Front Turnbuckle Assembly	1	1
5	SLP-00Q118	PF Lockout Plate	1	1
6	SLP-00N200	Main Frame Pivot Shaft	1	1
7	SLP-00P100	Front Steel Wheel Frame	1	1
	SLP-00P400	Quad Tire Frame (Optional)	1	1
8	SLP-00A000	Main Frame	1	1
9	SLP-00D000	Steel Wheel	4	4
10	SLP-00B200L	Scraper Blade Arm LH	3	3
	SLP-00B200R	Scraper Blade Arm RH	3	3
11	SLP-00P200	Front Scraper Blade	1	1
12	SLP-00J200	Pull Brace	2	2
13	SLP-00J100	Cross Brace - T.F. to Bucket	1	1
14	SLPF-00K007R	Pull Arm Tie Bar R.H.	1	1
	SLPF-00K007L	Pull Arm Tie Bar L.H.	1	1
15	SLP-00L200R	Bucket Side R.H.	1	1
	SLP-00L200L	Bucket Side L.H.	1	1
16	SLP-00L104	Side Bucket Adjustable Blade	2	2
17	SLPF-00L300	Tri Plane Wing Bucket (specify size)	1pair	1pair

Item	Part #	Description	40'	30'
18	SLPF-00F600	Wing Truss Rod Long	2	2
19	SLP-00H000	Tire Axle		
20	GWT-951508	9.5 X 15 8 Ply Tire / Wheel Assy	1	1
21	GHB-8X8HVY	8 X 8 Heavy Hub	2	2
22	GHC-35080WB	3.5 X 8 Welded Hyd. Cylinder	2	2
23	SLP-MTB	Bucket Turnbuckle Assembly	2	2
24	SLP-00F000	Center Cross Frame	1	1
25	SLP-00A400	Front Rod - 114"	2	2
26	GTB-12X96A	3/4" X 6" Turnbuckle Assembly	4	2
27	SLP-40G000	Rear Inside Frame- For 40' Units	1	0
28	SLP-00A500	Rear Rod - 126" - For 40' Units	2	0
29	SLP-00A300	L.H. Thread Stub End	4	2
30	SLPF-00C100	Rear Cross Frame	1	1
31	SLPF-00C200	Rear Wheel Arms Folding	1pair	1pair
32	SLP-00B100	Rear Steel Wheel Frame	2	2
33	SLP-00B203	Scraper Blade - Rear	2	2
34	TPP3152	1-11/16" Flange Bearing	8	8
35	UBNF14128S	Rear Frame 8" Square U-Bolt	4	4
36	UBNC05X22P	5/16" X 1-3/8" U-Bolt	2	1

Ordering Parts

We manufacture a quality product that requires very little maintenance or repair. However, should a part break or become damaged, our knowledgeable staff can make sure you receive the part(s) to put your unit back into operation.

Pull Frame Assembly

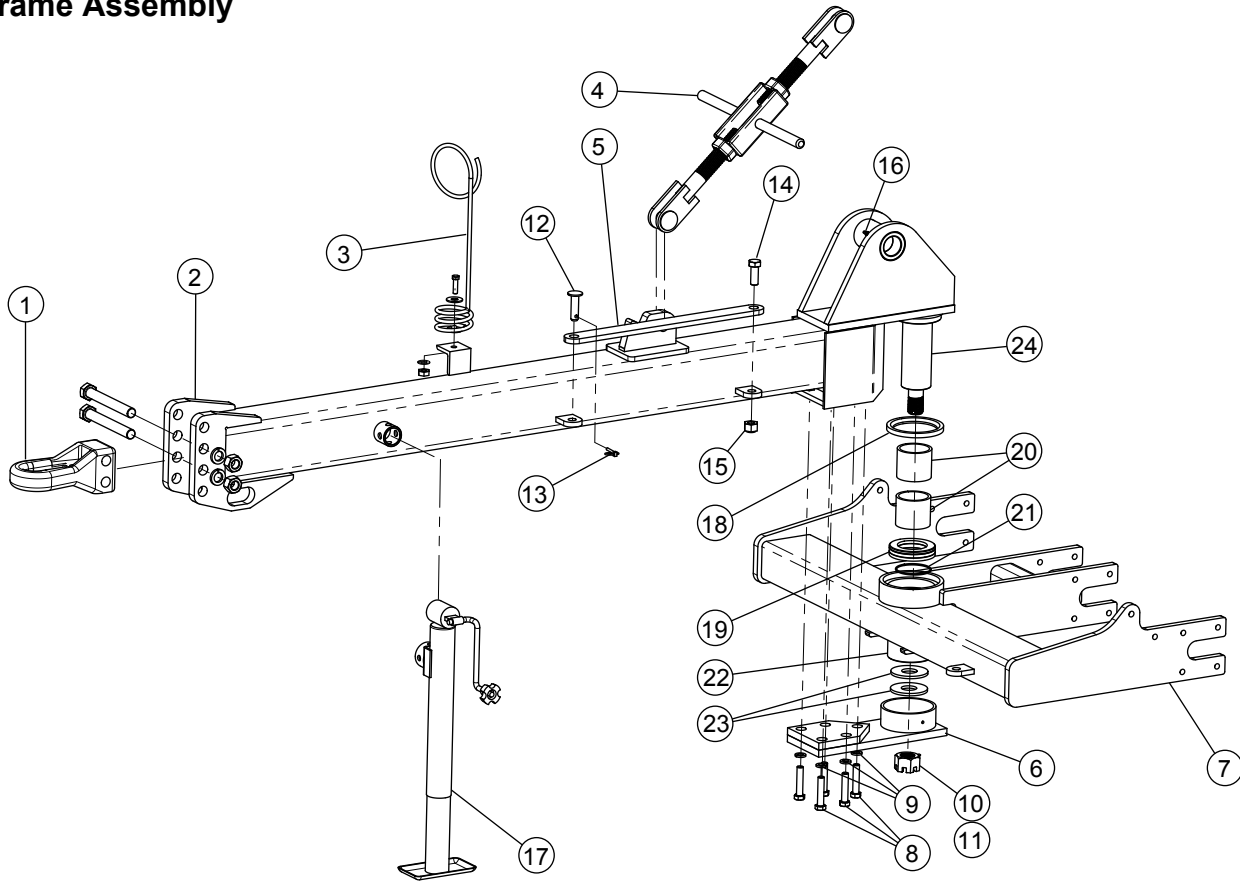

Item	Part #	Description	Q'ty
1	GMB-HITCHCA3H	Perfect Hitch CA 3 Heavy	1
2	SLP-00Q000	Tongue	1
3	GHD-HHOLD1	Hydraulic Line Support	1
4	SLP-00Q300	Front Turnbuckle Assembly	1
5	SLP-00Q118	PF Lockout Plate	1
6	SLP-00Q800	Front Wheel Frame Bearing Clamp	1
7	SLP-00P100	Front Steel Wheel Frame	1
	SLP-00P400	Quad Tire Frame (Optional)	1
8	CSNC512048	3/4" X 3" NC Gr.5 Cap Screw	5
9	LWASHER-12	3/4" Lock Washer	5
10	CANUT-24NF	1-1/2" NF Castle Nut	1
11	GPN-04X40C	1/4" Cotter Pin	1

Item	Part #	Description	Q'ty
12	GPN-12X040	3/4" X 2-1/2" Clevis Pin	1
13	GPN-040LYN	1/4" Lynch Pin	1
14	CSNC512040	3/4" X 2-1/2" Gr.5 NC Cap Screw	1
15	NYNUT-12NC	3/4" NC Nylon Lock Nut	1
16	GMB-ZERKTH	Threaded Grease Zerk	2
17	GJK-5KSW00	5000# Capacity Jack Stand 15 in	1
18	GBR-47394S	Oil Seal	1
19	GBR-48TB01	Thrust Bearing	1
20	GBR-4856GB	3" Housing Bushings	2
21	GMB-ORING46	O-Ring	1
22	SLP-00P300M	Front Bearing Housing Machined	1
23	SLP-00P114	1/4" Shaft Washer	2
24	SLP-00Q119	Pull Frame Bearing Shaft	1

Front Turnbuckle Assembly

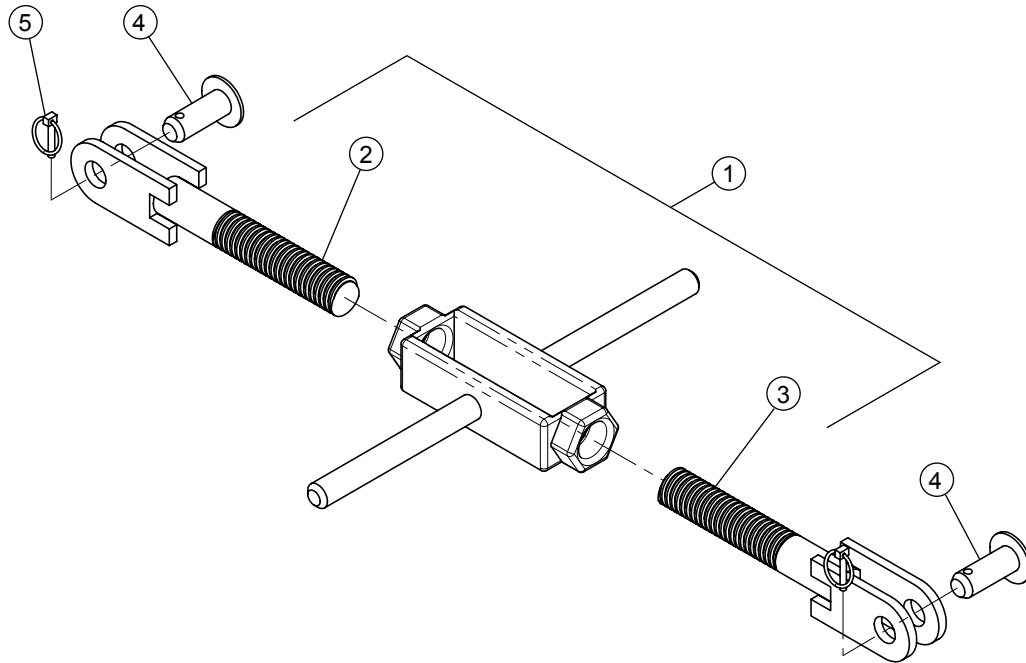

##	Part Number	Description	Q'ty
1	SLP-00Q300	Front Turnbuckle Assembly (includes items 2 and 3)	1
2	SLP-00Q400	Front Turnbuckle Stub R.H. Thread	1
3	SLP-00Q500	Front Turnbuckle Stub L.H. Thread	1
4	GPN-16X040	1" X 2-1/2" Clevis Pin	2
5	GPN-040LYN	1/4" Lynch Pin	2

Front Pivot Shaft Assembly

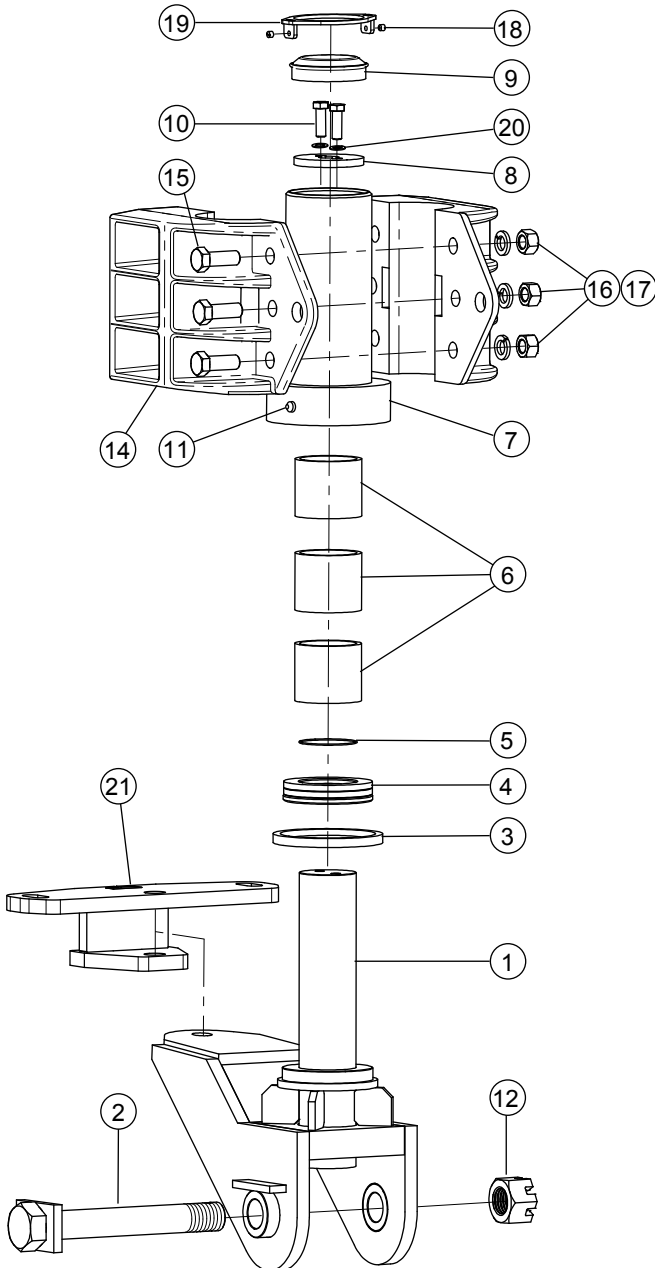

##	Part Number	Description	Q'ty
1	SLP-00N200	Front Pivot Shaft Weldment	1
	SLP-00N201	Front Pivot Shaft only	1
2	SLP-00N100	Pivot Shaft Clevis Pin	1
3	GBR-47394S	Oil Seal	1
4	GBR-48TB01	Thrust Bearing	1
5	GMB-ORING46	O-Ring	1
6	GBR-4856GB	Housing Bushing	3
7	SLP-00A600F	Front Bearing Housing	1
8	SLP-00A603	Shaft Cap	1
9	GBR-00GC01	Housing Dust (Grease)Cap	1
10	CSNC808024	1/2" X 1-1/2" Gr.8 Bolts	2
11	GMB-ZERKTH	Threaded Grease Zerk	1
12	CANUT-24NF	1-1/2" NF Castle Nut	1
13	GPN-04X40C	1/4" X 2-1/2" Cotter Pin	1
14	BC-200	Bearing Housing Half Clamp - welds to Main Frame	2
15	CSNC512032	3/4" X 2" Gr.5 Cap Screw	6
16	LWASHER-12	3/4" Lock Washer	6
17	HXNUT-12NC	3/4" NC Hex Nut	6
18	SSNC-05X06	5/16" x 3/8" NC Set Screw	2
19	SLP-00C300	Grease Cap Retainer	1
20	LWASHER-08	1/2" Lock Washer	2
21	SLP-00A800	Pivot Shaft Lockout	1

Front Wheel Frame Assembly

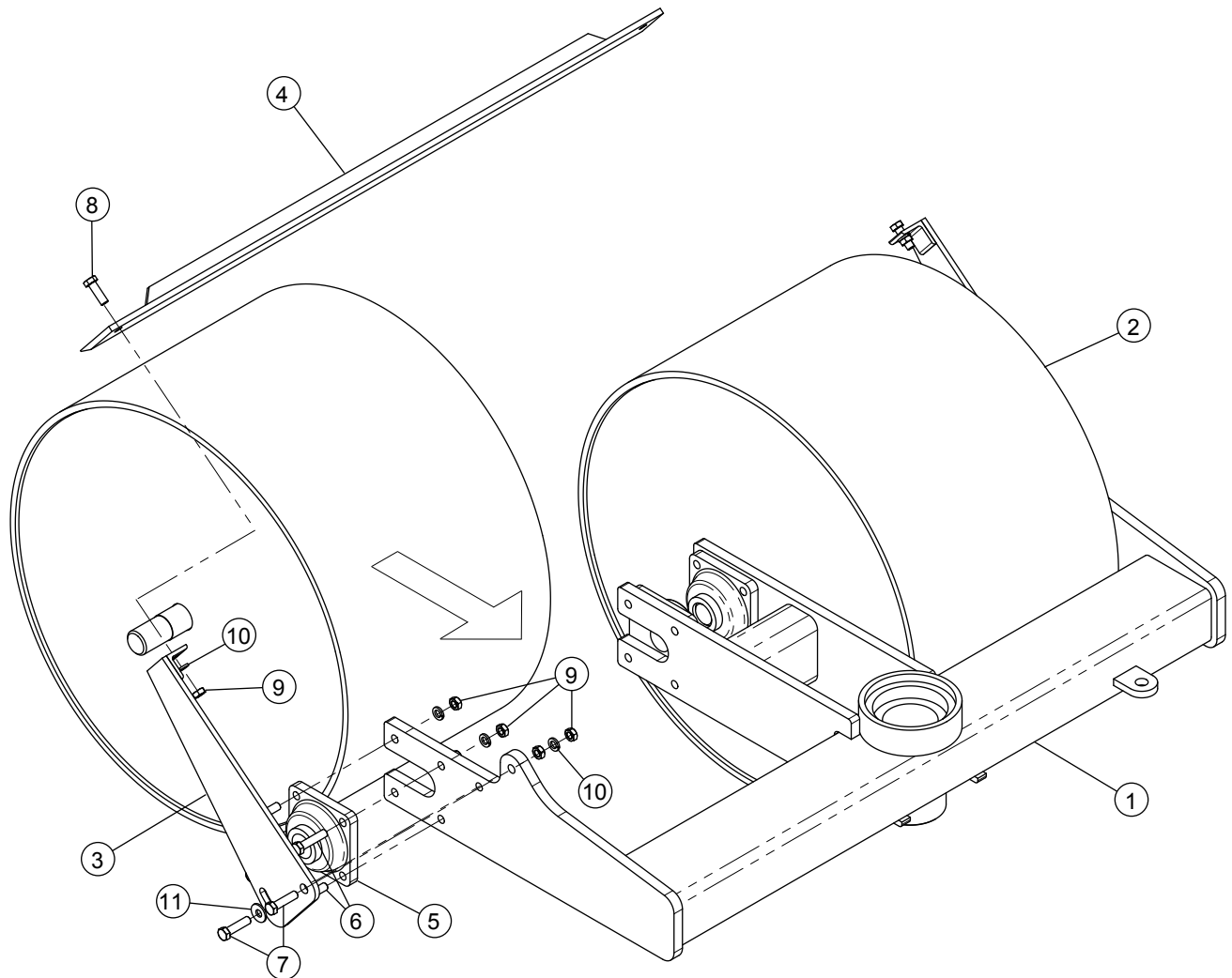

##	Part Number	Description	Q'ty
1	SLP-00P100	Front Steel Wheel Frame	1
2	SLP-00D000	Steel Wheels	2
3	SLP-00B200L	Scraper Blade Arm LH	1
	SLP-00B200R	Scraper Blade Arm RH	1
4	SLP-00P200	Front Wheel Scraper Blade	1
5	TPP 3152	1-11/16" Flange Bearing	4
6	CSNC508036	1/2" X 2-1/4" Gr.5 Cap Screw	16
7	CSNC508032	1/2" X 2" Gr.5 Cap Screw	4
8	CSNC508024	1/2" X 1-1/2" Gr.5 Cap Screw	2
9	HXNUT-08NC	1/2" Hex Nut	22
10	LWASHER-08	1/2" Lock Washer	22
11	FWASHER-08	1/2" Flat Washer	2

Quad Tire Option Assembly

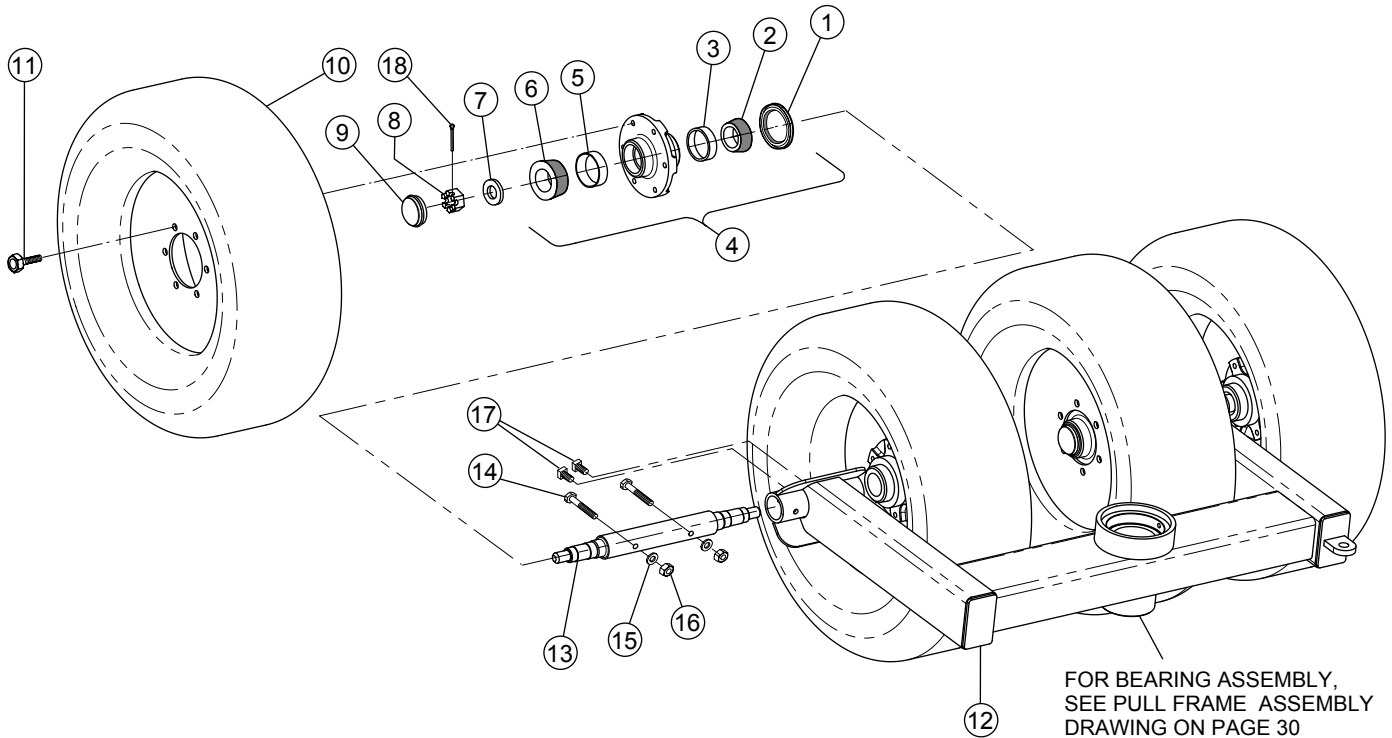

##	Part Number	Description	Q'ty
1	GHB-6X6GSL	Oil Seal for 6 on 6 Standard Hub	4
2	GHB-6X6ICN	Inner Bearing Cone for 6 on 6 Std. Hub	4
3	GHB-6X6IRC	Inner Bearing Race for 6 on 6 Std. Hub	4
4	GHB-6X6STD	Hub, 6 on 6 Std. Complete (includes items 1 through 6)	4
5	GHB-6X6ORC	Outer Bearing Race for 6 on 6 Std. Hub	4
6	GHB-6X6OCN	Outer Bearing Cone for 6 on 6 Std. Hub	4
7	FWASHER-14	7/8" Flat Washer	4
8	CANUT-14NC	7/8" NC Cattle Nut	4
9	GHB-6X6CAP	Dust Cap for 6 on 6 Std. Hub	4
10	GWT-951508	9.5 X 15 8 Ply Tire with Wheel	4
11	WHB-08X016	1/2" Wheel Bolt for 6 on 6 Std. Hub	24
12	SLP-00P400	Quad Tire Axle Frame	1
13	TBU-01G016	2" X 20-1/4" Removable Spindle	2
14	CSNC507056	7/16" X 3-1/2" NC Cap Screw	4
15	LWASHER-07	7/16" Lock Washer	4
16	HXNUT-07NC	7/16" Hex Nut	4
17	SSNCS08X16	1/2" X 1" NC Set Screw	4
18	GPN-04X28C	1/4" X 1-3/4" Cotter Pin	4

Bucket Linkage Assembly

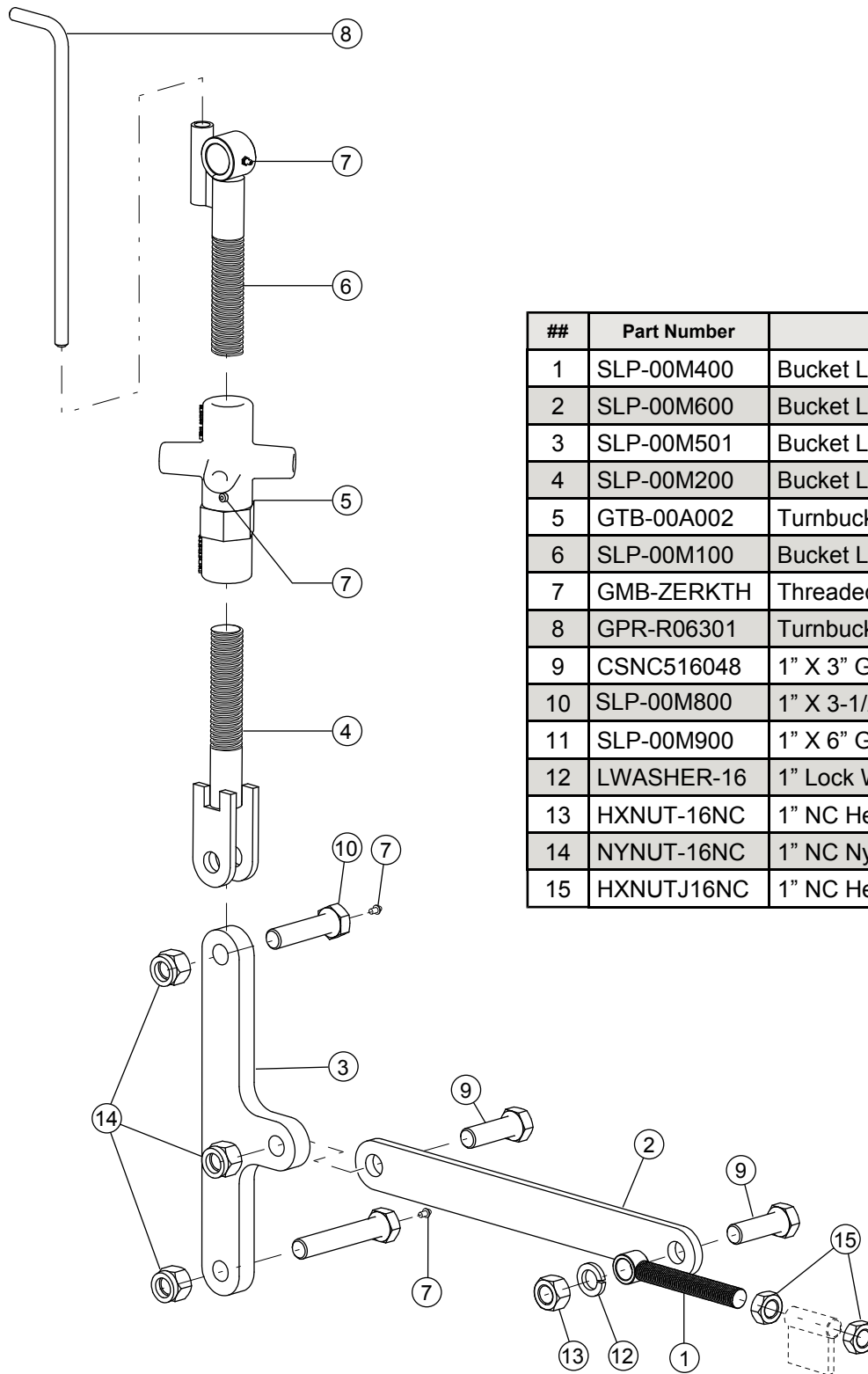

##	Part Number	Description	Q'ty
1	SLP-00M400	Bucket Linkage Adjustment Rod	2
2	SLP-00M600	Bucket Linkage Straight Link	2
3	SLP-00M501	Bucket Linkage T-Bar Link	2
4	SLP-00M200	Bucket Linkage Turnbuckle Bottom	2
5	GTB-00A002	Turnbuckle Casting Machined	2
6	SLP-00M100	Bucket Linkage Turnbuckle Top	2
7	GMB-ZERKTH	Threaded Grease Zerk	4
8	GPR-R06301	Turnbuckle Crank Rod	2
9	CSNC516048	1" X 3" Gr.5 Cap Screw	4
10	SLP-00M800	1" X 3-1/2" Gr.5 Cap Screw w/ Zerk	2
11	SLP-00M900	1" X 6" Gr.5 Cap Screw w/ Zerk	2
12	LWASHER-16	1" Lock Washer	2
13	HXNUT-16NC	1" NC Hex Nut	2
14	NYNUT-16NC	1" NC Nylon Lock Hex Nut	6
15	HXNUTJ16NC	1" NC Hex Jam Nut	4



Rigid Bucket Assembly

Item	Part #	Description	Q'ty All Units	Varied Q'ty and Lengths			
				12' Units	14' Units	16' Units	18' Units
1	SLP-12L100	Bucket 12 Ft. Units	1	144"			
	SLP-14L100	Bucket 14 Ft. Units	1		168"		
	SLP-16L100	Bucket 16 Ft. Units	1			192"	
	SLP-18L100	Bucket 18 Ft. Units	1				216"
2	SLP-BK3812	3/8" X 4" Single Beveled Blade Kit w/Fasteners 12'	1	143-1/2"			
	SLP-BK3814	3/8" X 4" Single Beveled Blade Kit w/Fasteners 14'	1		167-1/2"		
	SLP-BK3816	3/8" X 4" Single Beveled Blade Kit w/Fasteners 16'	1			191-1/2"	
	SLP-BK3818	3/8" X 4" Single Beveled Blade Kit w/Fasteners 18'	1				215-1/2"
	SLP-BK5012	1/2" X 6" Double Beveled Reversible Blade Kit w/Fasteners 12'	1	143-1/2"			
	SLP-BK5014	1/2" X 6" Double Beveled Reversible Blade Kit w/Fasteners 14'	1		167-1/2"		
	SLP-BK5016	1/2" X 6" Double Beveled Reversible Blade Kit w/Fasteners 16'	1			191-1/2"	
	SLP-BK5018	1/2" X 6" Double Beveled Reversible Blade Kit w/Fasteners 18'	1				215-1/2"
3	SLP-12K007L(R)	Bucket Pull Arm Brace 12' LH (RH)	1 of ea.	45-9/16"			
	SLP-14K007L(R)	Bucket Pull Arm Brace 14' LH (RH)	1 of ea.		52-5/16"		
	SLP-16K007L(R)	Bucket Pull Arm Brace 16' LH (RH)	1 of ea.			61-13/16"	
	SLP-18K007L(R)	Bucket Pull Arm Brace 18' LH (RH)	1 of ea.				71-1/2"
4	SLP-00J200	Pull Brace	2				
5	SLP-00J100	Cross Frame (Top Frame to Bucket)	1				
6	SLP-00K000L(R)	Bucket Pull Arm LH (RH)	1 of ea.				
7	SLP-00L200L(R)	Bucket Side LH (RH)	1 of ea.				
8	SLP-00L204	Bucket Side Adjustable Blade	2				
9	PBNC-10028	5/8" X 1-3/4" NC Plow Bolts		13	15	17	19
10	CSNC510032	5/8" X 2" Gr.5 NC Cap Screw	16				
11	FWASHER-10	5/8" Flat Washer	6	13	15	17	19
12	LWASHER-10	5/8" Lock Washer	16	13	15	17	19
13	HXNUT-10NC	5/8" NC Hex Nut	16	13	15	17	19
14	CSNC512032	3/4" X 2" Gr.5 NC Cap Screw	12				
15	LWASHER-12	3/4" Lock Washer	12				
16	HXNUT-12NC	3/4" NC Hex Nut	12				
17	CSNC516072	1" X 4-1/2" Gr.5 NC Cap Screw	2				
18	NYNUT-16NC	1" NC Nylon Lock Hex Nut	2				
19	GPN-16X048	1" X 3" Clevis Pin Red	2				
20	GPN-040LYN	1/4" Lynch Pin	2				

Rigid Bucket Assembly

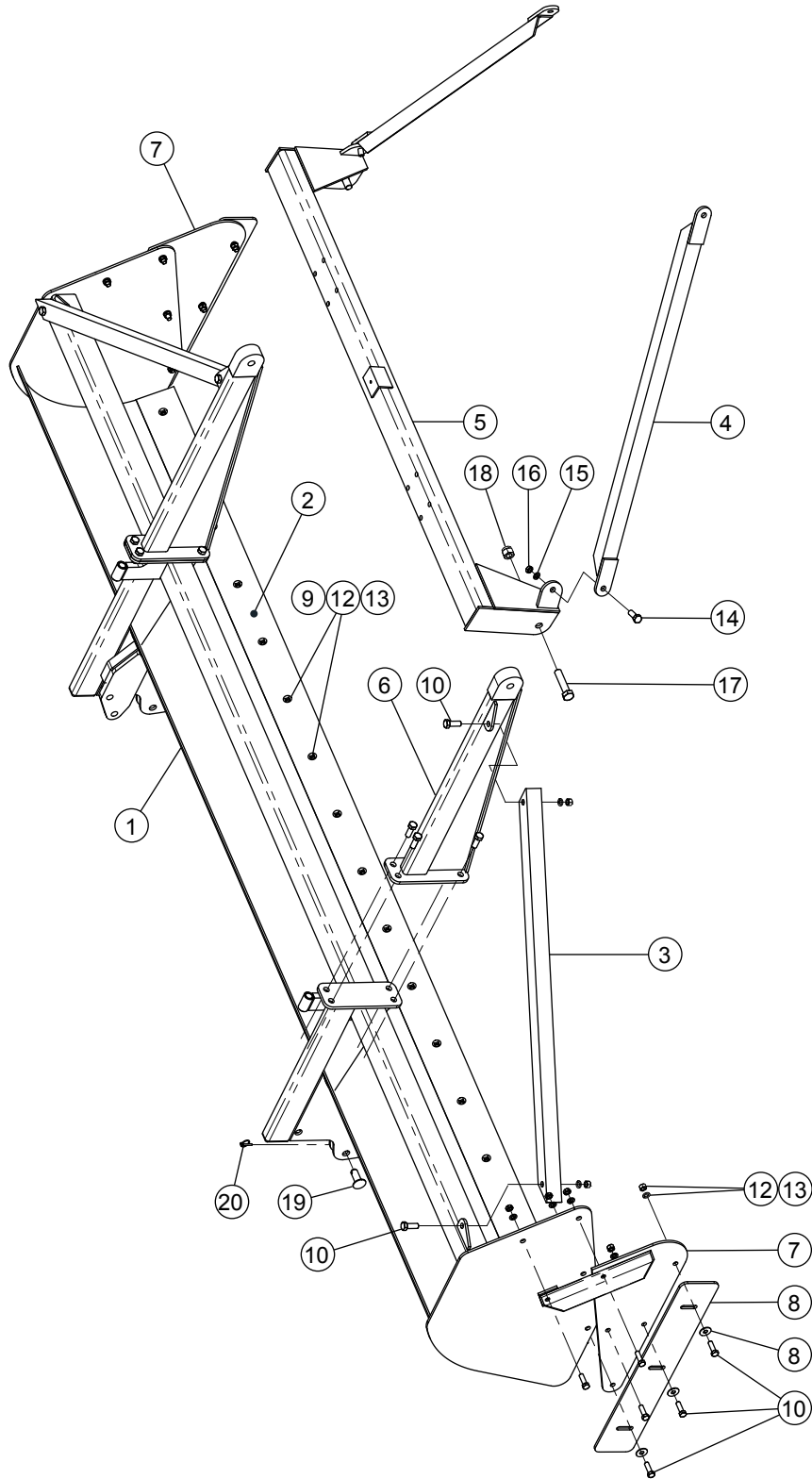



Folding Bucket Assembly

Item	Part #	Description	Q'ty All Units
1	SLPF-10L100	Main Bucket 10 Ft. - All Units	1
2	SLPF-07L300	Wing Bucket 7 Ft. - 24 Ft. Units	2
	SLPF-06L300	Wing Bucket 6 Ft. - 22 Ft. Units	2
	SLPF-05L300	Wing Bucket 5 Ft. - 20 Ft. Units	2
3	SLP-00J100	Cross Brace - Top Frame to Bucket	1
4	SLP-00J200	Pull Brace	2
5	SLP-00L200L	Bucket Side LH	1
	SLP-00L200R	Bucket Side RH	1
6	SLP-00L204	Bucket Side Adjustment Blade	2
7	SLP-10L125	Main Bucket Blade Shim 10 Ft. - All Units	1
	SLP-07L125	Wing Bucket Blade Shim 7 Ft. - 24 Ft. Unit	2
	SLP-06L125	Wing Bucket Blade Shim 6 Ft. - 22 Ft. Unit	2
	SLP-05L125	Wing Bucket Blade Shim 5 Ft. - 20 Ft. Unit	2
8	SLP-BK5024	1/2" X 6" Double Beveled Reversible Blade Kit w/Fasteners 24 Ft.	1
	SLP-BK5020	1/2" X 6" Double Beveled Reversible Blade Kit w/Fasteners 20 Ft.	1
9	CSNC510040	5/8" X 2-1/2" Gr.5 NC Cap Screw	2
10	CSNC510032	5/8" X 2" Gr.5 NC Cap Screw	12
11	PBNC-10028	5/8" X 1-3/4" NC Plow Bolts	Varies
12	LWASHER-10	5/8" Lock Washer	Varies
13	HXNUT-10NC	5/8" NC Hex Nut	Varies
14	FWASHER-10	5/8" Flat Washer	6
15	CSNC512032	3/4" X 2" Gr.5 NC Cap Screw	4
16	CSNC512040	3/4" X 2-1/2" Gr.5 NC Cap Screw	8
17	LWASHER-12	3/4" Lock Washer	2
18	HXNUT-12NC	3/4" NC Hex Nut	2
19	NYNUT-12NC	3/4" NC Nylon Lock Hex Nut	2
20	CSNC516040	1" X 2-1/2" Gr.5 NC Cap Screw	6
21	CSNC516072	1" X 4-1/2" Gr.5 NC Cap Screw	2
22	LWASHER-16	1" Lock Washer	8
23	HXNUT-16NC	1" NC Hex Nut	8
24	CSNC506040	3/8" X 2-1/2" Gr.5 NC Cap Screw	2
25	CSNC506064	3/8" X 4" Gr.5 NC Cap Screw	2
26	LWASHER-06	3/8" Lock Washer	4
27	HXNUT-06NC	3/8" NC Hex Nut	4
28	SLP-00K004	Pull Arm Plate (plate only)	2
29	SLPF-00K007L	Pull Arm Tie Bar LH	1
	SLPF-00K007R	Pull Arm Tie Bar RH	1
30	SLPF-00L804	Wing Hinge Pin	2
31	SLPF-00F000	Truss Rod Mast Cross Bar	1
32	SLPF-00F100	Truss Rod Mast Pivot Bushing	2
33	SLPF-00L600	Truss Rod Long	2
34	GTB-12X96W	Turnbuckle Welded Assy (includes body and short rod)	2
35	UBNC10X41S	5/8" NC Square U-Bolt	4
36	GPN-12X040	3/4" X 2-1/2" Clevis Pin	2
37	GPN-040LYN	1/4" Lynch Pin	2

Folding Bucket Assembly

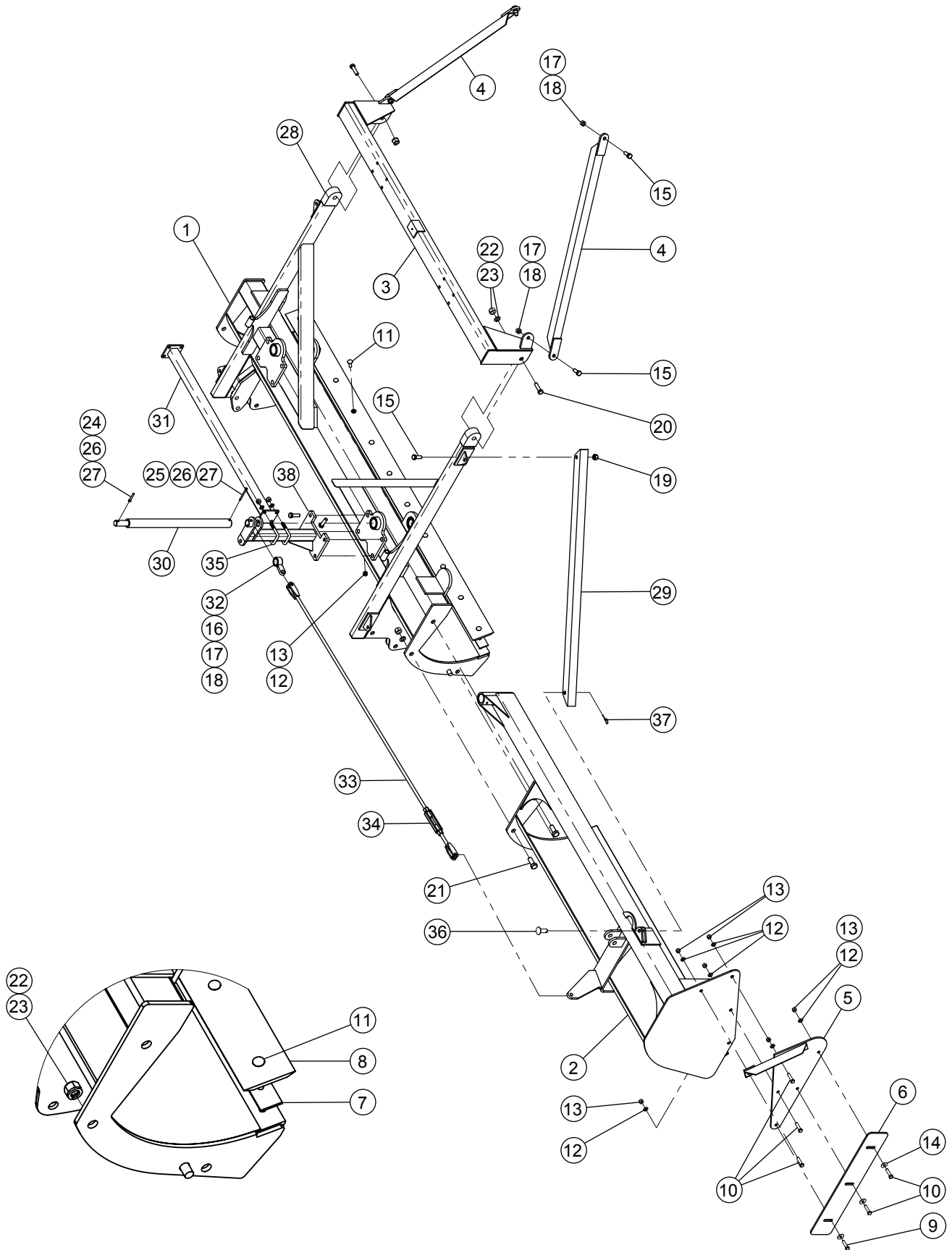

Bucket Blades Assembly

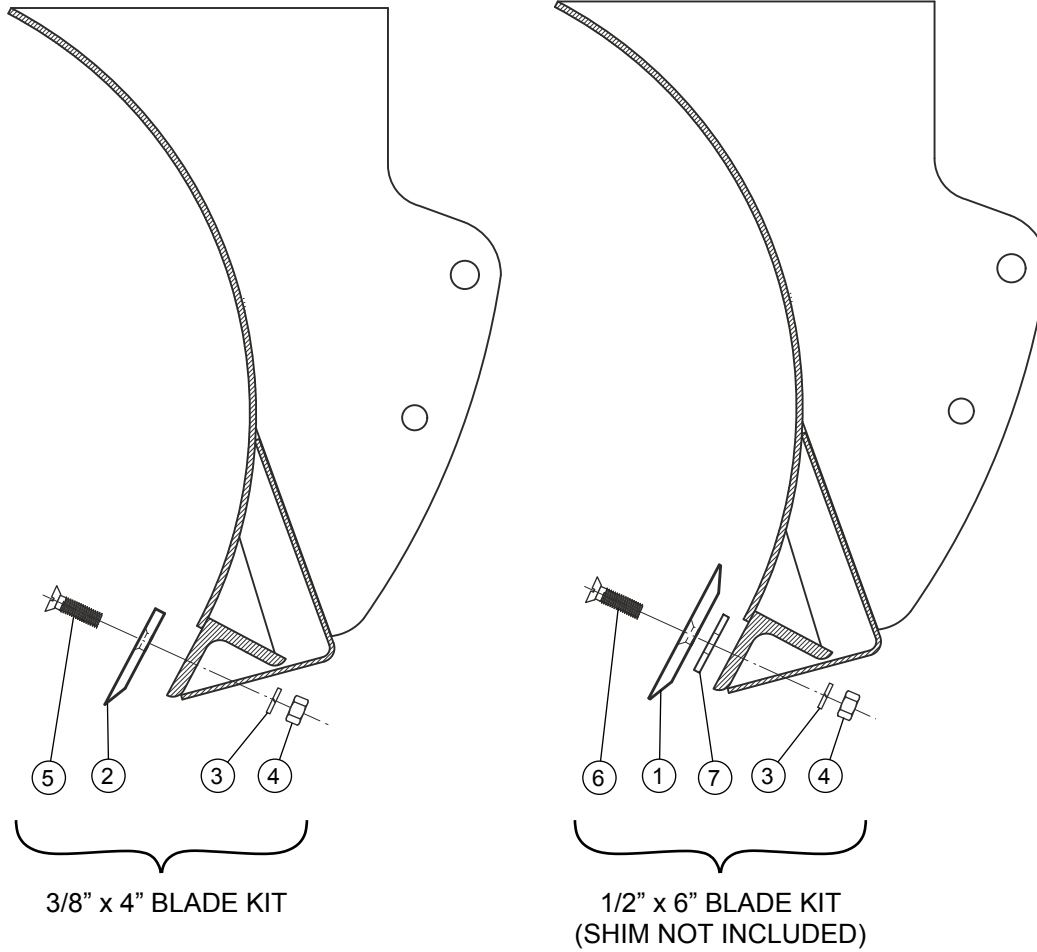

NOTE: SEE PAGES 36 AND 38 FOR ALL BLADE KIT SIZES.

##	Part Number	Description	Q'ty
1	SLP-00L124	1/2" X 6" Bucket Blade (specify size)	1
2	SLP-00L123	3/8" X 4" Bucket Blade (specify size)	1
3	LWASHER-10	5/8" Lock Washer	varies
4	HXNUT-10NC	5/8" NC Hex Nut	varies
5	PBNC-10028	5/8" X 1-3/4" NC Plow Bolt	varies
6	PBNC-10036	5/8" X 2-1/4" NC Plow Bolt	varies
7	SLP-00L125	Bucket Blade Shim - not included in the blade kit (Specify size)	1

Wheel Axle Assembly

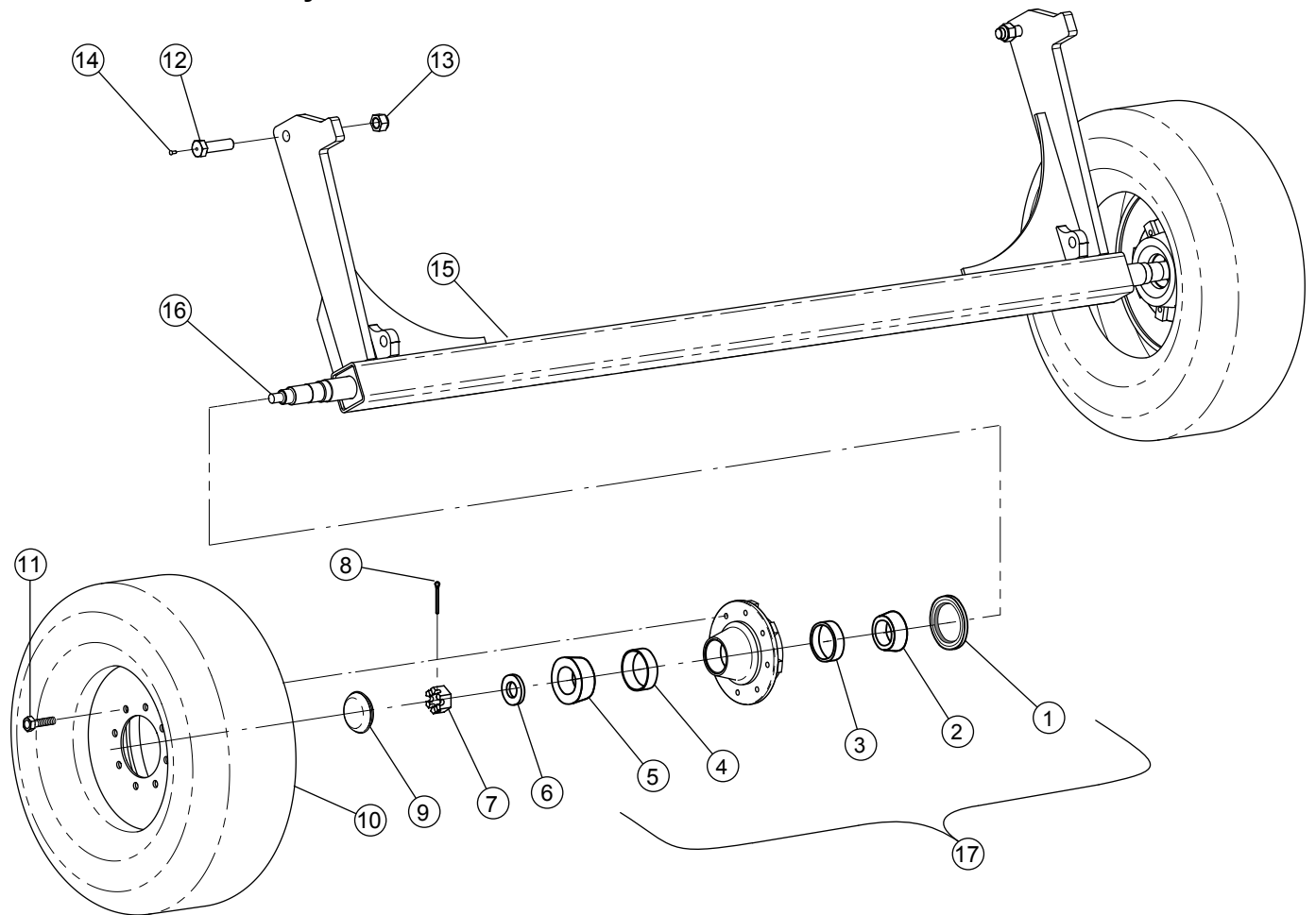

##	Part Number	Description	Q'ty
1	GHB-8X8GSL	Oil Seal for 8 on 8 Heavy Hub	2
2	GHB-8X8ICN	Inner Bearing Cone	2
3	GHB-8X8IRC	Inner Bearing Race	2
4	GHB-8X8ORC	Outer Bearing Race	2
5	GHB-8X8OCN	Outer Bearing Cone	2
6	GSP-14SPWA	7/8" Spindle Flat Washer	2
7	GSP-14CANT	7/8" Spindle Castle Nut	2
8	GPN-04X28C	1/4" X 1-3/4" Cotter Pin	2
9	GHB-8X8CAP	Dust Cap for 8 on 8 Heavy Hub	2
10	GWT-121614	12.5 X 16 14 Ply Tire with Wheel	2
11	WHB-09X018	Wheel Bolts for 8 on 8 Heavy Hub	16
12	SLP-00M800	1" X 3-1/2" Gr.5 NC Bolt with Zerk	2
13	NYNUT-16NC	1" NC Nylon Lock Hex Nut	2
14	GMB-ZERKDT	Pressed-In Grease Zerk	2
15	SLP-00H000	Tri Plane Wheel Axle	1
16	GSP-34248S	2-1/8" X 15-1/2" Single Spindle (includes items 6-8)	2
17	GHB-8X8HVY	Hub, 8 on 8 Heavy, Complete (incl. Items 1-5, 9)	1

Rear Steel Wheel Frame Assembly

Item	Part #	Description	Q'ty
1	SLP-00B100	Rear Steel Wheel Frame	2
2	SLP-00D000	Steel Wheel	2
3	SLP-00B200L	Scraper Blade Arm LH	2
	SLP-00B200R	Scraper Blade Arm RH	2
4	SLP-00B203	Scraper Blade	2
5	SLP-00B300	Locking Arm	2
6	SLP-00B304	Locking Arm Bearing Bushing	2
7	SLP-00A600R	Rear Frame Bearing Housing	2
8	SLP-00A603	Shaft Cap	2
9	GMB-ZERKDT	Pressed In Grease Zerk	2
10	GBR-4856GB	Housing Bushings	6
11	GMB-ORING46	2-7/8" O-Ring	2
12	GBR-48TB01	Thrust Bearing	2
13	GBR-47394S	Oil Seal	2
14	GBR-00CB01	Locking Arm Bearing (Centering Bearing)	2
15	GSR-CENT01	Locking Arm Spring (Centering Spring)	2
16	TPP3152	1-11/16" Flange Bearing	4
17	GBR-00GC01	Housing Dust Cap	2
18	CSNC508016	1/2" X 1" Gr.5 NC Cap Screw	2
19	CSNC508024	1/2" X 1-1/2" Gr.5 NC Cap Screw	4
20	CSNC508032	1/2" X 2" Gr.5 NC Cap Screw	8
21	CSNC508036	1/2" X 2-1/4" Gr.5 NC Cap Screw	18
22	FWASHER-08	1/2" Flat Washer	10
23	LWASHER-08	1/2" Lock Washer	30
24	HXNUT-08NC	1/2" NC Hex Nut	28
25	NYNUT-08NC	1/2" NC Nylon Lock Hex Nut	2
26	CSNC808024	1/2" X 1-1/2" Gr.8 NC Cap Screw	2
27	GMB-ZERKTH	Threaded Grease Zerk	2
28	SLP-00N101	Pivot Shaft	2
29	SLP-00B105	Rear Frame Shaft Collar	2

Rear Steel Wheel Frame Assembly

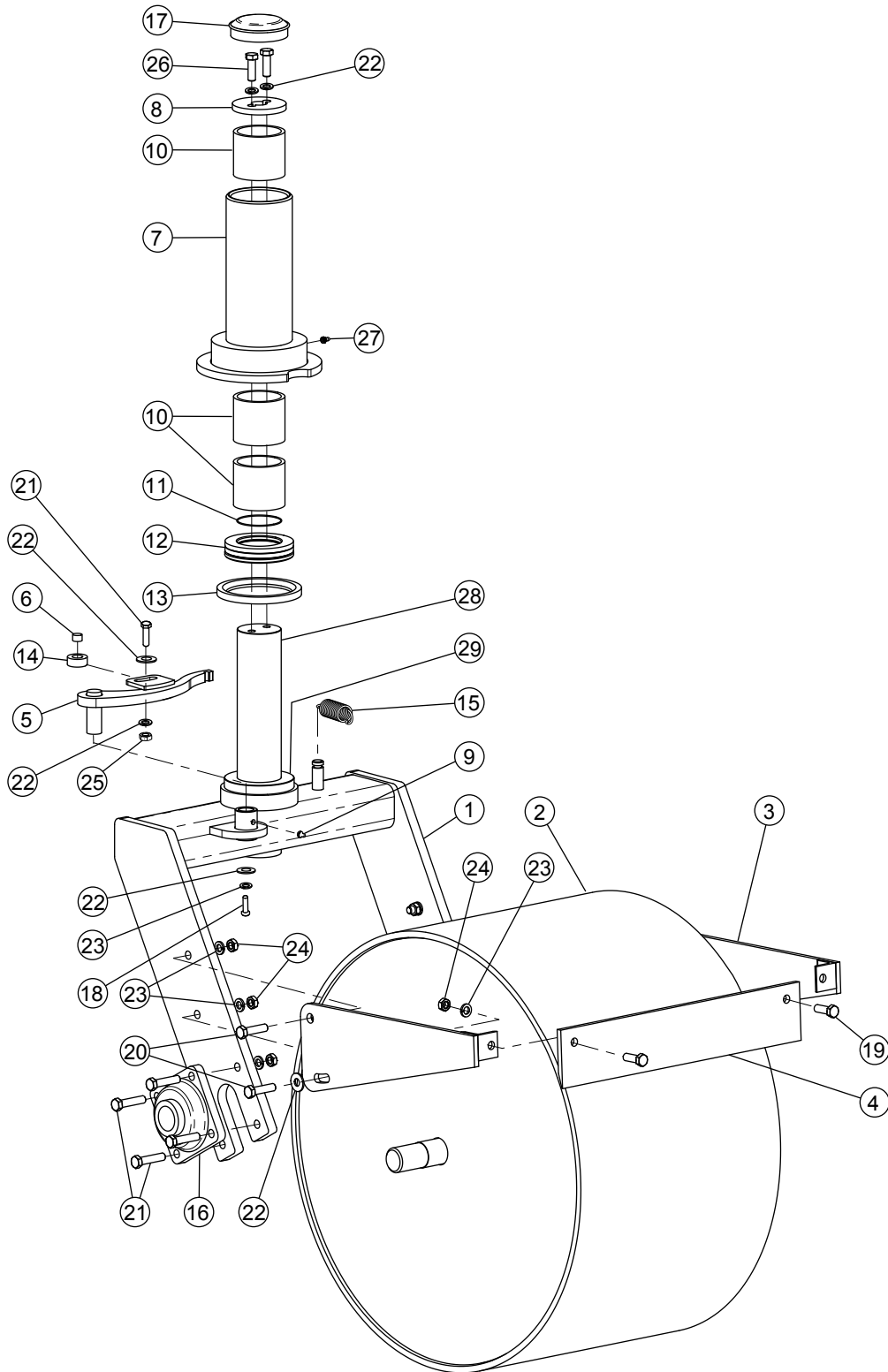

Folding Tri Plane Rear Cross Bar and Steel Wheel Mount Frames Assembly

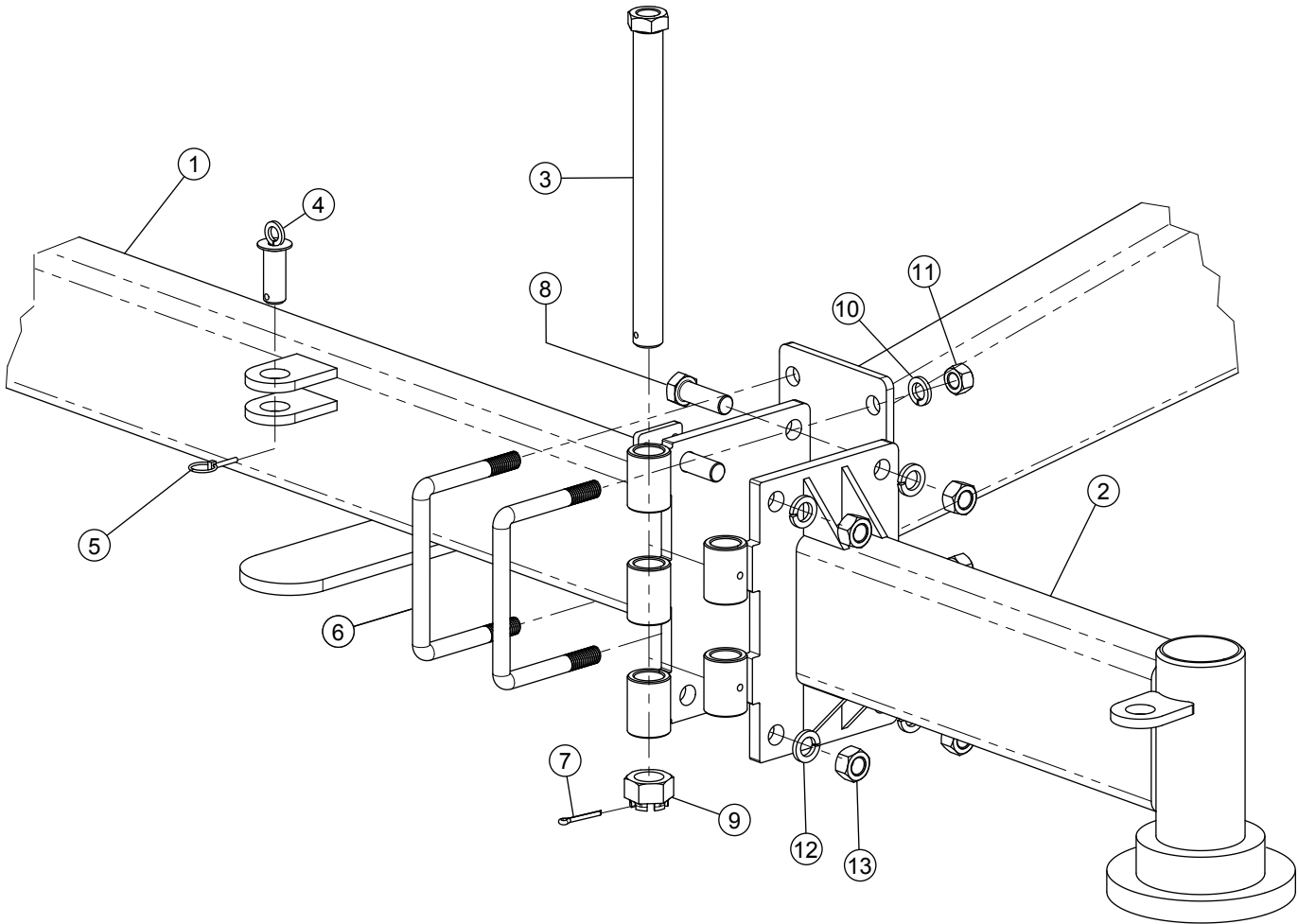

##	Part Number	Description	Q'ty
1	SLPF-00C100	Rear Cross Bar	1
2	SLPF-00C200L	Rear Steel Wheel Mount Frame LH	1
	SLPF-00C200R	Rear Steel Wheel Mount Frame RH	1
3	SLPF-00C500	Rear Frame Hinge Pin	2
4	GPN-18X044	1-1/8" X 2-3/4" Lockout Pin	2
5	GPN-040LYN	1/4" Lynch Pin	2
6	UBNF14128S	7/8" NF Square U-Bolt	4
7	GPN-05X48C	5/16" X 3" Cotter Pin	2
8	CSNC516048	1" X 3" Gr.5 NC Cap Screw	8
9	CANUT-24NF	1-1/2" NF Castle Hex Nut	2
10	LWASHER-14	7/8" Lock Washer	8
11	HXNUT-14NF	7/8" NF Hex Nut	8
12	LWASHER-16	1" Lock Washer	8
13	HXNUT-16NC	1" NC Hex Nut	8

Folding Tri Plane Front Wing Lockout Assembly

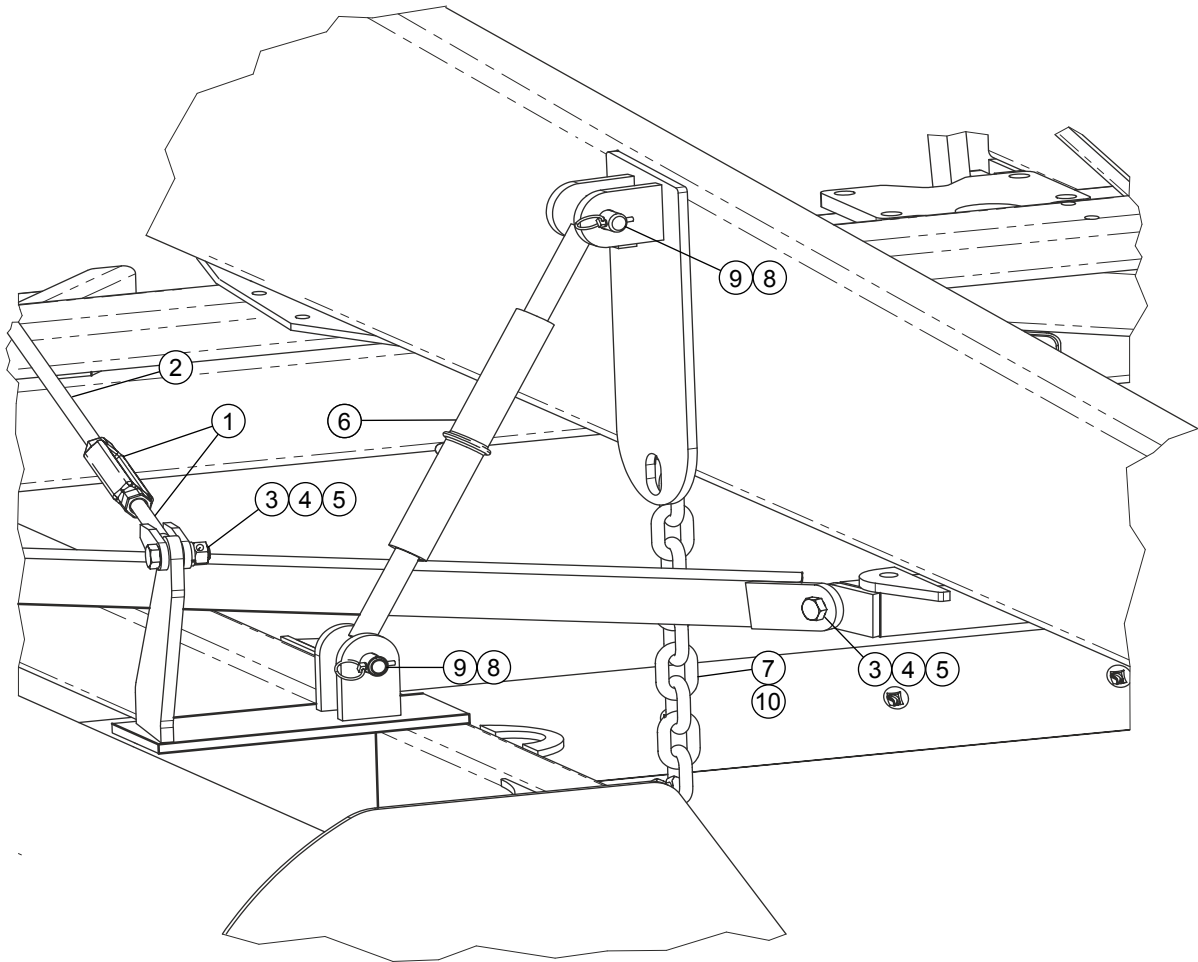

##	Part Number	Description	Q'ty
1	GTB-12X96W	3/4" X 6" Turnbuckle Assembly (Includes turnbuckle body and short rod)	2
2	SLPF-00F600	3/4" Long Truss Rod Weldment	2
3	CSNC512040	3/4" X 2-1/2" NC Gr.5 Cap Screw	4
4	LWASHER-12	3/4" Lock Washer	4
5	HXNUT-12NC	3/4" NC Hex Nut	4
6	GJK-CA0216	CA2 Top Link Ratchet	2
7	GMB-CH05PC	5/16" Safety Chain (5 Ft. Long)	2
8	GPN-040LYN	1/4" Lynch Pin	4
9	GPN-16X076	1" X 4-5/16" Top Link Pin	4
10	GMB-CH05HK	5/16" Chain Slip Hook	2

Tri Plane Hydraulic Diagram

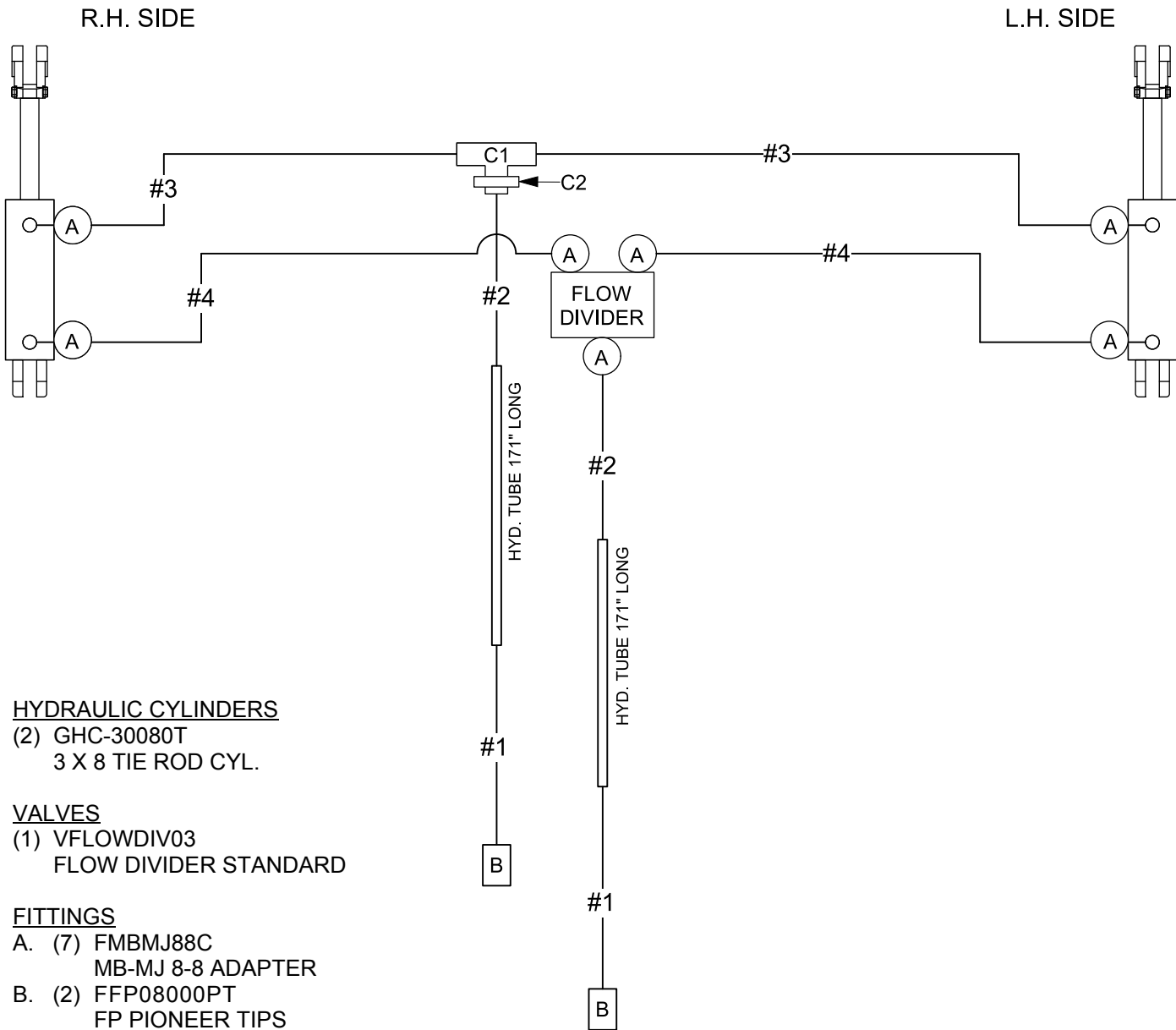

HYDRAULIC CYLINDERS

(2) GHC-30080T
3 X 8 TIE ROD CYL.

VALVES

(1) VFLOWDIV03
FLOW DIVIDER STANDARD

FITTINGS

A. (7) FMBMJ88C
MB-MJ 8-8 ADAPTER
B. (2) FFP08000PT
FP PIONEER TIPS
C1. (1) FMJHT8
MJ HT-8 BULKHEAD TEE
C2. (1) FHN8
HN-8 BULKHEAD NUT

HOSES (HKSLPJ - HOSE KIT)

#1 - (2) 1/2" MP -1/2" MJ 180" LONG
#2 - (2) 1/2" MJ -1/2" FJX 90 48" LONG
#3 - (2) 1/2" FJX -1/2" FJX45 65" LONG
#4 - (2) 1/2" FJX -1/2" FJX90 62" LONG

FRONT OF THE MACHINE

LIMITED WARRANTY STATEMENT

T.G. Schmeiser Co., Inc.

P.O. Box 1392 – Selma, CA 93662

Phone (559) 268-8128 Fax (559) 268-3279

T. G. Schmeiser Co., Inc. warrants each new Schmeiser® product to be free from defects in material and workmanship. This warranty is applicable only for the normal service life expectancy of the product or components, not to exceed twelve (12) consecutive months from the date of delivery of the new Schmeiser product to the original purchaser.

Genuine T. G. Schmeiser Co., Inc. replacement parts and components will be warranted for 90 days from date of purchase, or the remainder of the original equipment warranty period, whichever is longer.

Under no circumstances will it cover any merchandise or components thereof, which, in the opinion of the company, has been subjected to misuse, unauthorized modifications, alteration, an accident or if repairs have been made with parts other than those obtainable through T. G. Schmeiser Co., Inc.

The Company in no way warrants engines, batteries, cylinders, tires or other trade accessories since these items are warranted separately by their respective manufacturer. Expendable components such as points, shanks, blades, rings, bearings, teeth, and the like are excluded from this warranty.

Our obligation under this warranty shall be limited to repairing or replacing, free of charge to the original purchaser, any part that, in our judgment, shall show evidence of such defect, provided further that such part shall be returned within thirty (30) days from date of failure to T. G. Schmeiser Co., Inc., routed through the dealer and distributor from whom the purchase was made, transportation charges prepaid.

This warranty shall not be interpreted to render T. G. Schmeiser Co., Inc. liable for injury or damages of any kind or nature to person or property. This warranty does not extend to the loss of crops, loss because of delay in harvesting, or any expense or loss incurred for labor, substitute machinery, rental or for any other reason.

Except as set forth above, T. G. Schmeiser Co., Inc. shall have no obligation or liability of any kind on account of any of its equipment and shall not be liable for special or consequential damages. T. G. Schmeiser Co., Inc. makes no other warranty, expressed or implied, and, specifically, T. G. Schmeiser Co., Inc. disclaims any implied warranty or merchantability or fitness for a particular purpose. Some states or provinces do not permit limitations or exclusions of implied warranties or incidental or consequential damages, so the limitations or exclusion in this warranty may not apply.

This warranty is subject to any existing conditions of supply, which may directly affect our ability to obtain materials or manufacture replacement parts.

T. G. Schmeiser Co., Inc. reserves the right to make improvements in design or changes in specifications at any time, without incurring any obligation to owners of units previously sold.

No one is authorized to alter, modify or enlarge this warranty nor the exclusion, limitations and reservations.

**WARRANTY VOID IF NOT REGISTERED
WITHIN 30 DAYS OF PURCHASE DATE**



**P.O. Box 1392
Selma, CA 93662
(559) 268-8128
WEB: www.TGSchmeiser.com**

